

Miami-Dade County Building Department skyline header image

e-Permitting



MUNICIPAL INSPECTION REQUIREMENTS AND RECORD 07/29/2025
 MUNICIPAL NO.2025-061604 FOLIO: 3220220400020
 JOB SITE ADDRESS 14001 NW 82 AVE
 PROPOSED USE OFFICE - PROFESSIONAL BUILDINGS
 LEGAL MIAMI LAKES BUSINESS PARK 22-2 PB 149-15 T-19385
 APPLICATION TYPE ALTER INTERIOR 0 SQFT 0 UNITS 0 FLOORS
 OWNER NAME TGC LL8 LLC
 CONTRACTOR JOHNSON CONTROLS SECURITY SOLUTIONS LLC
 QUALIFIER FITZPATRICK JASON
 PERMIT TYPE MUNICIPAL ELEC
 CATEGORIES 0004 MUNICIPAL FIRE ALARM

DATE: 7/29/2025 PROCESS NUMBER: M2025016727 NEW *AMOUNT PAID 444.34
 FIRE 38109 ALTERATIONS 137.57 FIRE 1 FIRE ALARM UP 117.70
 FIRE 21 ALARM ACCP TE 331.58 FRWK 1 1ST FIRE MINO 92.89
 UBS1 1 BLDG 7.5% UPF 1.88 UPMU 25 UPFRONT FEE F 25.00

7/29/2025 15:14 BNZWEB1 182507296312 WEBIPAS 444.34

MUNICIPAL INSPECTION REQUIREMENTS AND RECORD 07/29/2025
 MUNICIPAL NO.2025-061604 PROCESS NO. M2025016727 FOLIO: 3220220400020
 JOB SITE ADDRESS 14001 NW 82 AVE
 PROPOSED USE OFFICE - PROFESSIONAL BUILDINGS

REQUIRED INSPECTIONS INIT DATE
 FIRE
 0004 FIRE ALARM
 209 FIRE FINAL

MUNICIPAL INSPECTION REQUIREMENTS AND RECORD 07/29/2025
 MUNICIPAL NO.2025-061604 PROCESS NO. M2025016727 FOLIO: 3220220400020
 JOB SITE ADDRESS 14001 NW 82 AVE
 PROPOSED USE OFFICE - PROFESSIONAL BUILDINGS

TO SCHEDULE A FIRE INSPECTION, PLEASE VISIT THE WEB AT
 WWW.MIAMIDADE.GOV/BUILDING OR WWW.MIAMIDADE.GOV/FIRE. YOU WILL
 NEED TO PROVIDE YOUR TEN DIGIT MUNICIPAL INSPECTION NUMBER AND
 INSPECTION TYPE. THE INSPECTION TYPE CAN BE FOUND ON YOUR
 INSPECTION REQUIREMENTS AND RECORDS CARD.

IF YOU HAVE ANY QUESTIONS OR CONCERNS REGARDING AN INSPECTION,
SCHEDULING A PRELIMINARY INSPECTION, OR LOAD BANK TEST
INSPECTION, PLEASE CALL FIRE PREVENTION AT 786-331-4800.

IF YOU HAVE ANY QUESTIONS OR CONCERNS REGARDING A PLAN REVIEW,
PLEASE CALL FIRE ENGINEERING AT (786) 315-2771.

****BE ADVISED THIS IS NOT A PERMIT. PERMIT IS TO BE ISSUED BY
YOUR CORRESPONDING MUNICIPAL BUILDING DEPARTMENT.**

[Back to Main Menu](#)

[BLDG Home Page](#) | [BLDG Main Menu](#) | [BLDG Permit Menu](#) | [BLDG Plans Processing Menu](#) | [Inspection Types](#) | [Address Format](#)

[Home](#) | [About](#) | [Phone Directory](#) | [Privacy](#) | [Disclaimer](#)

E-mail your comments, questions and suggestions to [Webmaster](#)

This page was last edited on: February 23, 2004

Web Site © 2004 Miami-Dade County.
All rights reserved.

PRO4200

Professional Series Access Modules

The PRO4200 professional series family of access control modules is designed for high density installations.

The PRO4200 professional series can be managed through WIN-PAK® integrated security suite for more advanced features such as Video integration, advance reporting, rules and photo badging, elevator control, touch-less access and mobile credential management.

Supporting up to 18 doors per enclosure and 34 doors per intelligent controller along with up to 100,000 card capacity, PRO4200 Series provide a combination of small installation footprint and superior cost per door ratio.

The new PRO42IC Intelligent Controller provides I/O support for 2 Doors*. The PRO42R1 provides I/O support for one card access reader, while the PRO42R2 support two card access readers. Both interface with the intelligent control module (PRO42IC). In the event that communication to the intelligent control module is lost, the card access readers be individually configured to allow entrance based on security needs. This customization allow or a be configured as secured, locked and unlocked. PRO4200 modules provide latest bi-directional and strong encrypted OSDP communication with the Access Control readers. For legacy and retrofit installations, Wiegand format is still supported.

The PRO42OUT interfaces provide up to 16, Form C, 30VDC, 2A relay output controls depending if the board is rack or tile-mounted, power fail and panel tamper when tile mounted. Relays may be used for elevator control, status annunciation and for general facility control, such as door monitoring.



The PRO42IN interfaces provide 16 supervised alarm inputs and a dedicated power fail and panel tamper when tile mounted. An analog to digital converter samples the input values and the digitized result is filtered and processed. Filter parameters are configurable for each input point, resulting in the ability to specify a custom End-Of-Line (EOL) resistance value, sensitivity range and timing parameter.

The PRO4200 Series of access modules are designed to accommodate various mounting options. Units can be mounted in a rack configuration (PRO22ENC1, PRO22ENC2 and PRO22ENC5) when space is limited, or in a tile-mount configuration (PRO22ENC3).

- The PRO22ENC1 is a wall-mounted enclosure rack unit (See picture)
- The PRO22ENC2 is a 19" rack-mounted enclosure rack unit
- The PRO22ENC5 is a rack unit which fits inside a customer's enclosure

** The new PRO42IC Intelligent Controller provides I/O support for up to 2 doors with a maximum of 2 OSDP readers per door or 1 Wiegand reader per door. The PRO42R1 provides I/O support for up to 1 door and the PRO42R2 supports up to 2 doors. The PRO42R1 and PRO42R2 will support a maximum of 2 OSDP readers per door or 1 Wiegand reader per door.*

FEATURES AND BENEFITS



- Modular design fits a wide variety of applications
- Up to 9 modules, power-supply and battery can be accommodated by the PRO22ENC1, PRO22ENC2 and PRO22ENC5 (no battery) enclosures
- User programmable relay outputs allow for specific control needs
- User programmable alarm inputs offer flexible system configuration and control



- RS485 communication to all modules
- Analog to digital converter technology provides digital filtering and input conditioning
- Dedicated cabinet tamper and power monitor inputs
- Supports the choice of normally open, normally closed, supervised, and non-supervised circuits
- Supports a wide range of



- System off-line modes customizable per reader include secured access, locked (no access), and unlocked (full-access)
- Supports multiple reader and card formats for maximum flexibility and security options
- Operating modes includes locked, unlocked, secure access, card only, card and PIN, card or PIN and PIN only



- Any combination of 16 downstream I/O or readers modules may be connected to the PRO42IC RS485 ports. 4,000 ft (1,250 m) total bus length per port
- Supports over 50,000 transaction buffer



SPECIFICATIONS

MODULE SPECIFICATIONS	PRO4200 SERIES SINGLE READER MODULE (PRO42R1)	PRO4200 SERIES DUAL READER MODULE (PRO42R2)
PORT	Reader port 12/24VDC @ 500mA, OSDP; Wiegand; Dt/Clk*	2 Reader port 12/24VDC @ 300mA, OSDP; Wiegand; Dt/Clk*
KEYPAD	Keypad multiplexed with card data	
WIRE SUPPORT	Two-wire or one-wire bi-color LED support	
BUZZER SUPPORT	Buzzer support only with one-wire LED control	
ALARM INPUTS	2 supervised, general purpose alarm inputs with programmable circuit type	8 supervised, general purpose alarm inputs with programmable circuit type (only 6 supervised inputs available when using PRO22ENC1, PRO22ENC2 and PRO-22ENC5 enclosures)
OUTPUT RELAYS (DOOR STRIKE(S))	1 output relay, form C, 5A 40 VDC	2 output relay, form C, 2A 30 VDC
OUTPUT RELAYS	1 general purpose output relay, form C, 5A 30 VDC	2 general purpose output relay, form C, 5A 30 VDC
MOUNTING	Designed to be tile-mounted using the PRO22ENC4 enclosure	N/A
ALARM INPUT PROPERTIES		
INPUTS	Inputs may be assigned to door related functions or general purpose I/O	
CIRCUIT TYPE	Circuit type - normally open, normally closed, non-supervised, supervised (with standard 1K or custom end-of-line resistance 200-10K)	
LINE CONDITIONING	Line conditioning - programmable sensitive hold time	
OUTPUT CONTROL PROPERTIES		
OUTPUTS	Outputs may be assigned to door related functions or general purpose I/O	
RELAY RATING	The relay(s) are rated to handle the inductive loads of door locking devices S-4 SUPPRESSOR CABLE TO THE DOOR OPENER	
CONFIGURABLE	Configurable as standard (energize to activate) or fail-safe (de-energize to activate)	
PULSE TIME	1-42,400 seconds, 1-255 for door relays	
RS485 PORT	RS485 port, 4,000 ft (1,250m) total bus length	
STANDARD SPEED	38.4 Kbps	
MODULE SPECIFICATIONS	PRO4200 SERIES SIXTEEN RELAY OUTPUT MODULE (PRO42OUT)	PRO4200 SERIES SIXTEEN ALARM INPUT MODULE (PRO42IN)
ALARM INPUTS	2 dedicated (unsupervised) alarm inputs for tamper detection and power loss (tile-mounted only)	
ALARM INPUTS	N/A	16 general purpose inputs with programmable circuit type
OUTPUT RELAYS	12 general purpose output relays, form C, 5A 30 VDC (16 are available when using PRO22ENC3 tile-mounted enclosure)	2 general purpose, form C, 5A 30 VDC relays (only one available when using PRO22ENC1, PRO22ENC2 and PRO22ENC5)
OUTPUT CONTROL PROPERTIES		
OUTPUT	All 16-relay outputs in the tile-mount configuration (1 rack mount) are available for general purpose I/O	Both relay outputs are available for general purpose I/O
DRY CIRCUIT LOGIC	The 5A relays are rated to handle dry circuit logic (Resistive)	Both relay outputs are rated to handle dry circuit logic (Resistive)
PULSE TIME	1-32,400 seconds	
CONFIGURABLE	Configurable as standard (energize to activate) or fail-safe (de-energize to activate)	N/A
ALARM INPUT PROPERTIES		
INPUTS	2 dedicated for tamper detection and power loss	All 16 inputs may be assigned to door related functions or general purpose I/O 2 dedicated for tamper and power loss
CIRCUIT TYPE	N/A	Circuit type - normally open, normally closed, non-supervised, supervised (with correct EOL)
LINE CONDITIONING	N/A	Line conditioning - programmable sensitivity and hold time
COMMUNICATION FEATURES		
MEASUREMENTS	RS485 port, 4,000 ft (1,250m) total bus length per port	
SPEED	38.4 Kbps	

BENEFITS

- Anti-passback support – free pass and exempt flags, last area accessed, last reader accessed and time/date of last access
- Modular hardware architecture provides flexibility and expansion capabilities
- Large, local controller database allows access control decisions to be made by controller in real time without the need to communicate to the server
- ADA compliant allowing expanded door times selectable per reader
- Scalable architecture ensures optimal performance with a seamless upgrade path to accommodate future growth beyond its initial installation
- Four-state alarm input circuits - normally opened, normally closed, non-supervised, supervised (w/EOL)
- Rack or tile mounting options available
- Alarm conditioning with programmable sensitivity and hold time
- Selectable reader states include card and PIN, card or PIN, card only, or PIN only
- Power Supply supports 120 or 230 VAC
- System off-line modes customizable per reader include secured access, locked (no access), and unlocked (full-access)
- Supports multiple reader and card formats for maximum flexibility and security options
- Supports Wiegand and/or OSDP communication
- Enhanced Cyber Security
- Port based network access control using 802.1X
- Host communications protected by TLS 1.2/1.1 or AES-256/128

PRO4200 CONFIGURATION

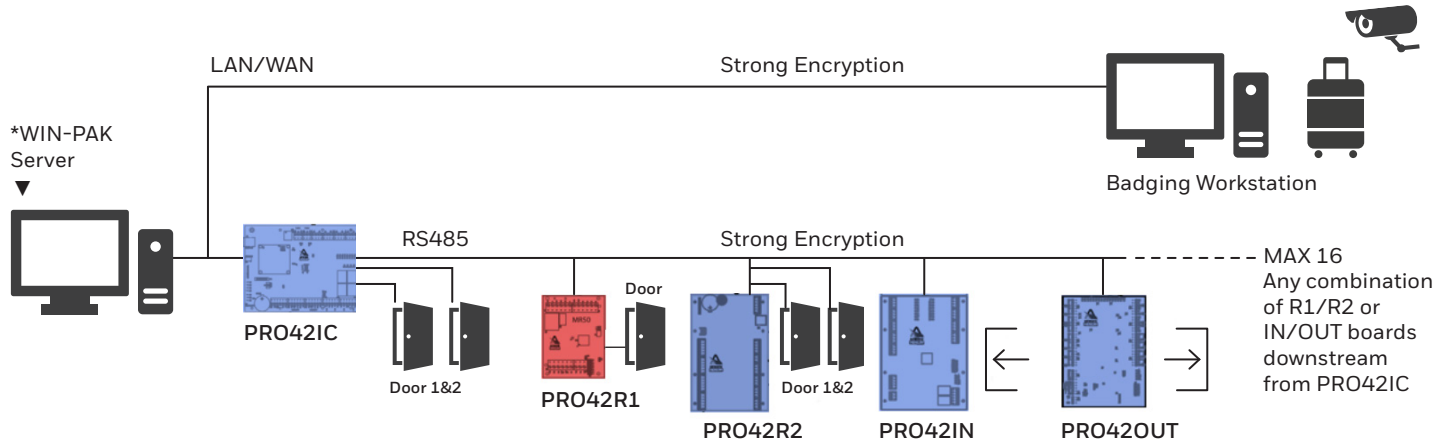

RED boards = Mercury Series 3

BLUE boards = Honeywell PRO4200 modules

*WIN-PAK 4.8.2 or higher supports Legacy Mode which includes all feature sets of the PRO3200 Series.

*Native support in WIN-PAK coming soon (PRO42IC On-Board Door support, OSDPV2, TLS1.2).

MODULE	READERS	PRO22ENC1		PRO22ENC3	
		INPUTS	OUTPUTS	INPUTS	OUTPUTS
PRO42R1	2 OSDP 1 Wiegand	N/A	N/A	2	2
PRO42R2	4 OSDP 2 Wiegand	6	4	10**	6
PRO42OUT	0	0	12	2**	16
PRO42IN	0	16	1	18**	2

****Two are used to monitor Power and Tamper (Dedicated)**

PRO22ENC1 = 9 Board Capacity/PRO22ENC3 = 2 Board Capacity



SPECIFICATIONS

DIMENSIONS / BOARDS

- **PRO42R1**
2.75" H x 4.25" W x 1.0" D
(70mm x 108mm x 25mm)
- **PRO42IC, PRO42R2; PRO42IN;
PRO42OUT**
9.0" H x 5.5" W x 1.0" D
(230mm x 140mm x 25mm)

ENCLOSURES

- **PRO22ENC1**
13.9" H x 17" W x 9" D
(353 mm x 432mm x 229 mm)
- **PRO22ENC2**
13.9" H x 18.9" W x 9" D
(353 mm x 480 mm x 229 mm)
- **PRO22ENC3**
14" H x 16" W x 4" D
(356 mm x 406 mm x 102 mm)
- **PRO22ENC4**
8.37" H x 7.63" W x 7.63 D
(213 mm x 194 mm x 194 mm)
- **PRO22ENC5**
9.35" H x 16.85" W x 5.6" D
(237 mm x 428 mm x 142 mm)

ENVIRONMENT

- Temperature: 0°C to 49°C* operational;
-55°C to 85°C storage
- Humidity: 5 to 85% RHNC

WIRE REQUIREMENTS

- **Power**
twisted pair, 18 AWG
- **Ethernet**
F(S)TP/CAT7, 300 ft (100m) max
- **RS485**
22- 24 AWG, 4,000 ft (1,200m) max, two
twisted pairs with shield (F(S)TP/CAT7)
- **Alarm Input**
twisted pair, 30 ohms max

ENCLOSURES

- **PRO22ENC1**
(Wall-mount) Capacity: 9 modules.
Power supply and battery not included
- **PRO22ENC2**
(19" Rack-mount) Capacity: 9 modules.
Power supply and battery not included
- **PRO22ENC3**
(Tile-mount) Capacity: 2 modules. Power
supply and battery included
- **PRO22ENC4**
(Tile-mount) Capacity: 1 module
(PRO42R1 only). Power supply and
battery included
- **PRO22ENC5**
(Cage only for custom enclosures)
Capacity: 9 modules. Power supply and
battery not included



PRO42IC



PRO42R2

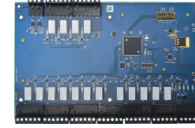

PRO42OUT



PRO42IN

PRO4200 CONTROLLERS

PRO42IC	PRO4200 Intelligent Controller
PRO42R1	PRO4200 single reader module
PRO42R2	PRO4200 Dual Reader Module
PRO42OUT	PRO4200 16 Relay Output Module
PRO42IN	PRO4200 16 Alarm Input Module

PRO-SERIES ENCLOSURES

PRO22ENC1	(Wall-mount) Capacity: 9 modules. Power supply and battery not included
PRO22ENC2	(19" Rack-mount) Capacity: 9 modules. Power supply and battery not included
PRO22ENC3	(Tile Mount) Capacity: 2 modules. Power supply and battery included
PRO22ENC4	(Tile-mount) Capacity: 2 modules.(PRO42R2 only). Power supply and battery not included
PRO22ENC5	(Cage only for custom enclosures) Capacity: 9 modules. Power supply and battery not included

PRO4200 STARTER KIT WITH SOFTWARE

PRO42SKD10*	10 Door Starter Kit (1) PRO42E1D8 with WIN-PAK SE Software
--------------------	--

* Coming soon

PRO4200 EXPANSION KITS

PRO4E1D4*	Door Kit: (1) PRO42R2, (2) S-4, and (1) PRO42E1EN
PRO4E1D6*	6 Door Kit: (2) PRO42R2, (4) S-4, and (1) PRO42E1EN
PRO4E1D10*	10 Door Kit: (4) PRO42R2, (8) S-4, and (1) PRO42E1EN

OPTIONAL ACCESSORIES

PRO22DCC	Daisy Chain cable required for PRO22ENC1, PRO22ENC2 and PRO22ENC5
PRO42PSU120	Rack-mounted power supply for PRO22ENC1, PRO22ENC2 and PRO22ENC5. Requires PRO22BAT1
PRO22BAT1	Battery, 7AH 12V

NETWORK KITS

PRO42E1EN	Includes: PRO22ENC1, PRO42IC, PRO42PSU120, PRO22BAT1 and PRO22DCC
PRO42E2EN	Includes: PRO22ENC2, PRO42IC, PRO42PSU120, PRO22BAT1 and PRO22DCC

Honeywell Commercial Security

715 Peachtree Street NE
Atlanta, GA 30308
1.800.323.4576

THE
FUTURE
IS
WHAT
WE
MAKE IT



AL600ULACM

Overview

AL600ULACM converts a 115VAC 60Hz input into eight (8) independently controlled 12VDC or 24VDC Fail-Safe and/or Fail-Secure outputs with a total of 6 amp continuous supply current. These power outputs can be converted to dry form “C” contacts. Outputs are activated by an open collector sink or normally open (NO) dry trigger input from an Access Control System, Card Reader, Keypad, Push Button, PIR, etc. This unit will route power to a variety of access control hardware devices including Mag Locks, Electric Strikes, Magnetic Door Holders, etc. The outputs will operate in both Fail-Safe and/or Fail-Secure modes. This unit is designed to be powered by one common power source (factory installed) which will provide power for both the board operation and locking devices, or two (2) totally independent power sources, one (1) providing power for board operation and the other for lock / accessory power. The FACP Interface enables Emergency Egress, Alarm Monitoring, or may be used to trigger other auxiliary devices. The fire alarm disconnect feature is individually selectable for any or all of the eight (8) outputs.

Specifications

Input:

- Input 115VAC 60Hz rated @ 3.5 amp.
- Power supply input options:
 - a) One (1) common power input for ACM8 and lock power (factory installed).
 - b) Two (2) isolated power inputs - One (1) to power the ACM8 and one (1) for lock accessory power, (external power supply is required). Current is determined by the power supply connected, not to exceed a maximum of 10 amp total.
- Eight (8) Access Control System trigger inputs.

Input options:

 - a) Eight (8) normally open (NO) inputs.
 - b) Eight (8) open collector inputs.
 - c) Any combination of the above.

Output:

- 12VDC or 24VDC @ 6 amp supply current.
- Eight (8) independently controlled outputs.

Output options:

 - a) Eight (8) Fail-Safe and/or Fail-Secure power outputs.
 - b) Eight (8) form “C” 5 amp rated relay outputs
 - c) Any combination of the above.
- Eight (8) auxiliary power outputs (unswitched)
- Output ratings:
 - Fuses are rated @ 3.5 amp.
- Filtered and electronically regulated outputs (built-in power supply).

Supervision:

- AC fail supervision (form “C” contacts).
 - Notification trigger is selectable for 30 seconds (factory set) or 6 hours.
- Low battery and battery presence supervision (form “C” contact).

Features:

- Fire Alarm disconnect (latching or non-latching) is individually selectable for any or all of the eight (8) outputs.
- Fire Alarm disconnect input options:
 - a) Normally open (NO) or normally closed (NC) dry contact input.
 - b) Polarity reversal input from FACP signaling circuit.
- Alarm output relay indicates that FACP input is triggered (form “C” contact rated @ 1 amp 28VDC).
- Short circuit and thermal overload protection.

Visual Indicators:

- Red LEDs indicate outputs are triggered (relays energized).
- Green LED indicates FACP disconnect is triggered.
- AC input and DC output LED indicators.

Battery Backup:

- Built-in charger for sealed lead acid or gel type batteries.
- Power Supply Board maximum charge current 0.7 amp.
- Automatic switch over to stand-by battery when AC fails.
- Zero voltage drop when unit switches over to battery backup (AC failure condition).

Electrical:

- Operating temperature: 0° C to 49° C ambient.
- ACM8 board main fuse is rated at 10 amp.
- BTU/Hr.:
 - 12VDC: 36.85 BTU/Hr.
 - 24VDC: 73.70 BTU/Hr.

Mechanical:

- Enclosure Dimensions (L x W x H approx.): 15.5” x 12” x 4.5” (393.7mm x 304.8mm x 114.3mm).
- Enclosure accommodates up to two (2) 12AH batteries.
- Product weight (approx.): 10.3 lbs. (4.67 kg).
- Shipping weight (approx.): 11.6 lbs. (5.26 kg).

Agency Approvals



UL Listed for Access Control Systems Units
(UL 294).

MEA Approved

MEA - NYC Department of
Buildings Approved.



CUL Listed - CSA Standard C22.2
No.205-M1983 Signal Equipment.



CSFM - California State Fire
Marshal Approved.

Enclosure Dimensions (H x W x D approximate):

15.5" x 12" x 4.5" (393.7mm x 304.8mm x 114.3mm)

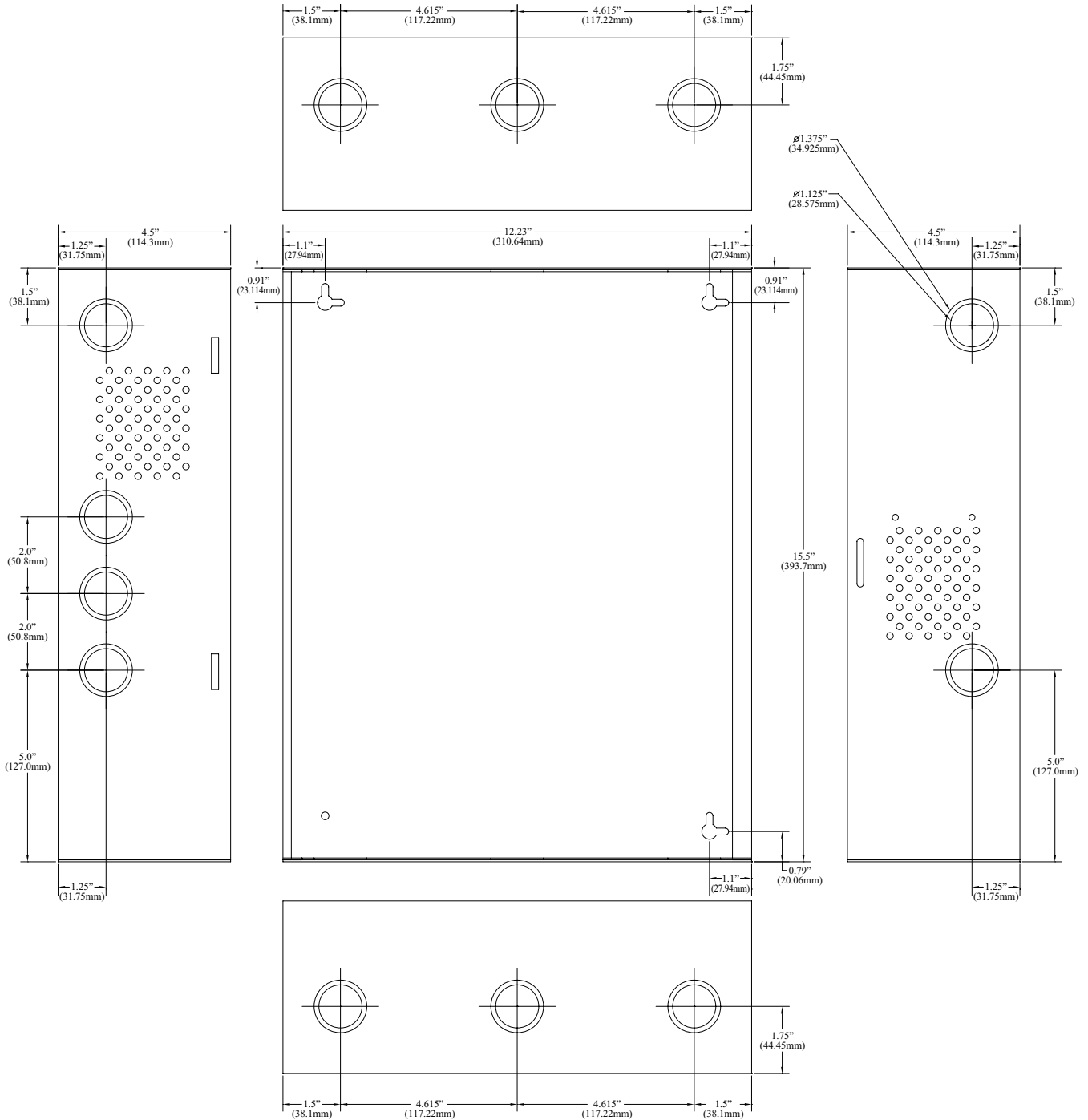

HES[®] 8000 Series No-Cut Electric Strikes

Retrofit solutions to electrify
cylindrical and mortise locksets

ELECTRONIC SECURITY HARDWARE HES PRODUCTS

Experience a safer
and more open world

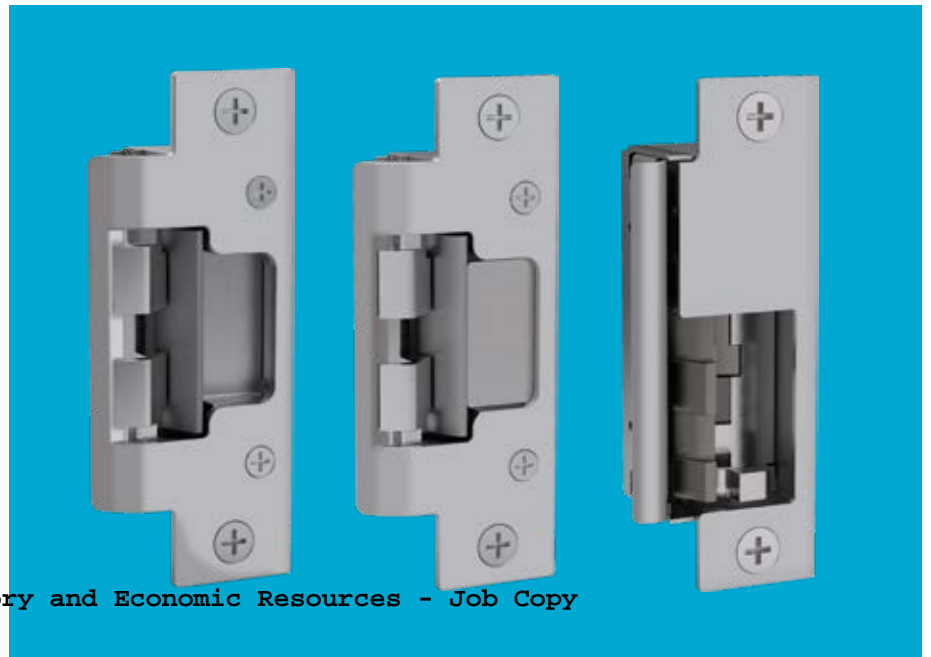

The HES 8000 Series offers compact, high performance electric strikes featuring a unique concealed design for cylindrical or mortise locksets.

No cutting on the frame is required, which means less time spent installing the strike. Simply remove the existing strike plate, adjust the vertical alignment to the latchbolt centerline, and install.

Ideal for aluminum, wood and hollow metal applications in office spaces, interior entries, stairwells, and other openings requiring electronic access control.



HES 8000

Works with Cylindrical Locksets up to a 5/8" Throw Latchbolt



Cylindrical Locksets



HES 8000

Works with Cylindrical Locksets up to a 5/8" Throw Latchbolt



Cylindrical Locksets



Fire Rated



HES 8000

Works with Mortise Locksets without a Deadbolt up to 3/4" Throw Latchbolt
Full pocket shims for horizontal adjustment



Mortise Locks without Deadbolt



Fire Rated

Saves Time

- No cutting in to the face of the frame
- Accommodates door sag with patented vertical adjustability

Concealed Design

- Fits in standard ANSI prep
- Completely concealed in frame
- Available in seven finishes



Specifications for all HES 8000 Family Strikes

Certifications

- ANSI/BHMA, A156.31 Grade 1
- UL 1034 burglary-resistant listed and suitable for outdoor use
- **UL 294 listed**
- RoHS Compliant

Electrical (DC Continuous Duty)

- Dual voltage 12/24 VDC
- 240 mA at 12VDC/120 mA at 24 VDC

Features

- No cutting required
- Vertical adjustability to accommodate door sag and misalignment
- Tamper resistant
- Non-handed
- Internally mounted solenoid
- SecuriCare five-year, no-fault, no questions asked warranty
- Addition of HES SMART Pac® III extends warranty to 10 years



		HES 8000	HES 8300	HES 8500	COMPETITOR
FRAME APPLICATION	Hollow Metal	✓	✓	✓	✓
	Wood	✓	✓		✓
	Aluminum	✓	✓		
	No-Cut	✓	✓	✓	✓
	Vertical adjustment	✓	✓		
	Horizontal Adjustment			✓	
	Cylindrical Locksets	✓	✓		✓
HOLDING FORCE	Mortise Locksets			✓	
	Static Strength 1,500 lbs	✓	✓	✓	✓
	Dynamic Strength 70 ft-lbs	✓	✓	✓	✓
ELECTRICAL	12 VDC Current Draw	240mA	240mA	240mA	300mA
	24 VDC Current Draw	120mA	240mA	240mA	150mA
	Dual Voltage 12/24 VDC Continuous Duty	✓	✓	✓	✓
	Field Selectable (Fail Secure/Fail Safe)	✓	✓	✓	✓
SPECIFICATIONS	UL1034 Burglary Resistant Listed (Indoor)	✓	✓	✓	
	UL1034 Burglary Resistant Listed (Outdoor)	✓	✓	✓	
	UL 294 Listed	✓	✓	✓	
	UL 10C Fire rated – Class A, 3 Hour Single Door		✓	✓	
	RoHS Compliant	✓	✓	✓	
	Cycle Testing	1M	1M	1M	250,000
	Finish Options	7	7	7	1
	Monitoring Type	Latchbolt Status Only	Latchbolt Status Only	Latchbolt & Strike Status	Latchbolt Only
Warranty	Five-year no questions asked	Five-year no questions asked	Five-year no questions asked	One-year limited	



Grade 1



SecuriCare Warranty



Field Selectable (Fail secure / Fail safe)



Dual Voltage 12/24



PoE Friendly



Outdoor Rated



Burglary Rated

The ASSA ABLOY Group is the global leader in access solutions. Every day, we help billions of people experience a more open world.

ASSA ABLOY Opening Solutions leads the development within door openings and products for access solutions in homes, businesses and institutions. Our offering includes doors, frames, door and window hardware, locks, perimeter fencing, access control and service.



How to Order

Series	Model	Finish*	Option (s)
8000	—	— 630	— LBM
8000	C* Complete Electric Strike; Includes the 801 and 801A faceplates	605 Bright Brass	LBM Latchbolt Monitor
8300		606 Satin Brass	
		612 Satin Bronze	
		613 Bronze Toned	
		629 Bright Stainless Steel	
		630 Satin Stainless Steel	
BLK Black			
8500		605 Bright Brass	LBM Latchbolt Monitor
		606 Satin Brass	
		612 Satin Bronze	LBSM Latchbolt & Strike Monitor
		613 Bronze Toned	
		629 Bright Stainless Steel	
630 Satin Stainless Steel			

*Complete Pacs are only available in the 630 finish

ELECTRONIC SECURITY HARDWARE

HES | Securitron

USA

800 626 7590 | assaabloyesh.com

customerservice.esh@assaabloy.com | techsupport.esh@assaabloy.com | orders.esh@assaabloy.com

CANADA

800 461 3007 | assaabloydss.ca

sales.dss.ca@assaabloy.com | orders.dss.ca@assaabloy.com

Connect with ASSA ABLOY Electronic Security Hardware

  @assaabloyesh   ASSA ABLOY Electronic Security Hardware

Patent pending and/or patent www.assaabloydss.com/patents

Miami Dade County Department of Regulatory and Economic Resources - Job Copy

3225016727, Hanchett Entry Systems, Inc. is a Hanchett Entry Systems, Inc. group company. All rights reserved. Reproduction in whole

3:14:23 PM or in part without the express written permission of Hanchett Entry Systems, Inc. is prohibited. ESH-HES-59-0819

COMBINED CUT SHEET.pdf

3/4" & 1" Steel Door Recessed Switch Set



WWW.GRISK.COM

180 / 184 / 8080-T Series



- ◆ Recessed magnetic contact
- ◆ 12" #22AWG leads or screw terminals
- ◆ Longer leads, zip cord or jacketed cable upon request
- ◆ Built in E.O.L. Resistors and Diodes upon request
 - ◆ Supervisory Loops upon request
 - ◆ Colors white, brown, gray, black
 - ◆  Indicates U.L. 10C Fire Rated



180-12



184-12 CE





8484-T



8080-T

Part Numbers

		<u>Closed Loop</u>	<u>Open Loop</u>	<u>SPDT</u>	<u>DPDT</u>
Standard Gap up to 1/2" on steel*	3/4" Dia.	180-12 	185-12	190-12	195-12
	1" Dia.	C € {184-12}	189-12	194-12	C € {199-12}
	3/4" Dia.	8080-T	8585-T		
	1" Dia.	8484-T	8989-T		
Wide Gap 3/4"+ on steel*	3/4" Dia.	180-12WG 	185-12WG	190-12WG	195-12WG
	1" Dia.	184-12WG 	189-12WG	194-12WG	199-12WG
	3/4" Dia.	8080-TWG	8585-TWG		
	1" Dia.	8484-TWG	8989-TWG		

7/8" Diameter also available. P/N 81-12 & 81-12WG, white or black only. Call the factory for more information.

INSTALLATION APPLICATIONS

The GRI 180-12 is the industry standard 3/4" diameter recessed steel door switch set with 12" leads. The innovative GRI 8080-T series is a 3/4" diameter recessed switch set designed for residential, commercial and industrial doors and frames. The shorter length terminals makes the installation of the set quick and simple.

WARRANTY: Lifetime warranty against workmanship, material and factory defects.

GEORGE RISK INDUSTRIES, INC.
G.R.I. PLAZA
KIMBALL, NE 69145



1-800-445-5218
1-800-523-1227
(308) 235-4645
FAX (308) 235-3561
E-MAIL: sales@grisk.com

3/4" & 1" Steel Door Recessed Switch Set

WWW.GRISK.COM

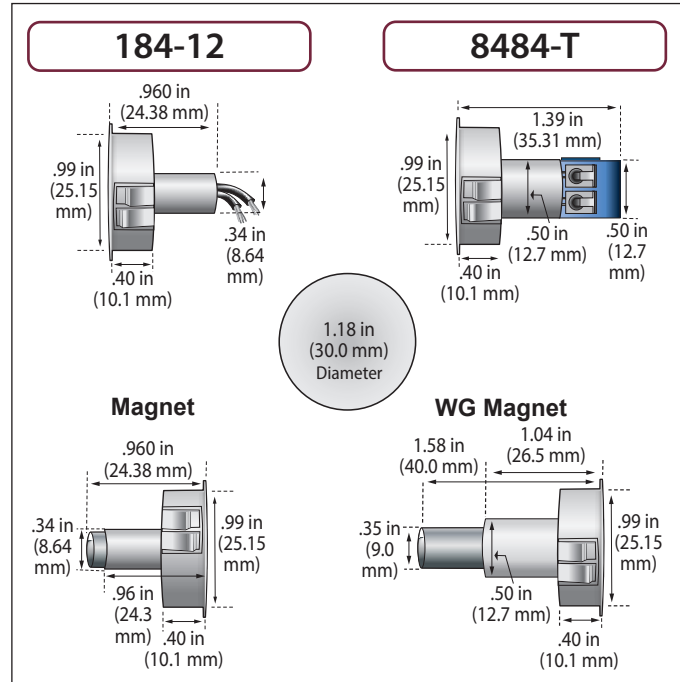
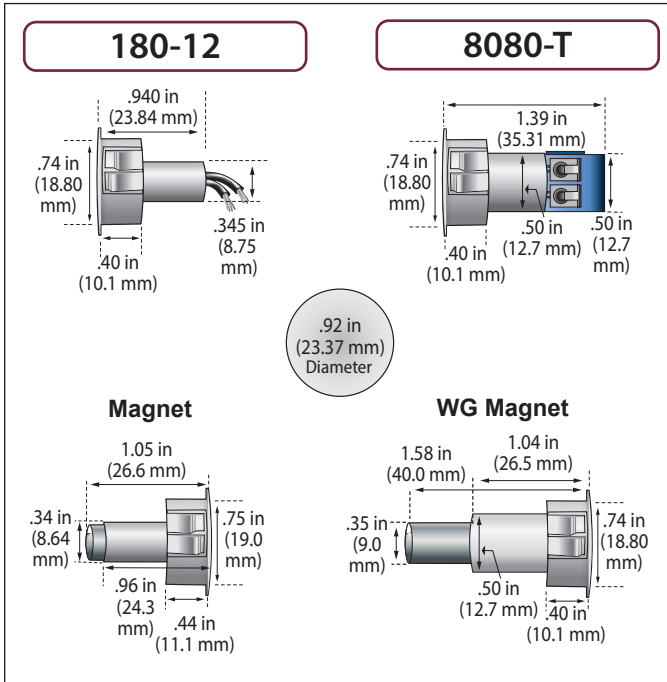

GRI PRODUCTS MEET OR EXCEED THESE MINIMUM GENERAL SPECIFICATIONS:

Part Number	Loop Type	Electrical Configuration	Reed Form	Maximum Initial Contact Resistance (Ω)	Max. Contact Rating (W)	Max. Switching Voltage (VDC)	Max. Switching Current (A)
180-12	Closed	N/O	A	.150	10	200	.400
180-12WG	Closed	N/O	A	.150	10	200	.400
184-12	Closed	N/O	A	.150	10	200	.400
184-12WG	Closed	N/O	A	.150	10	200	.400
8080-T	Closed	N/O	A	.150	10	160	.400
8080-TWG	Closed	N/O	A	.150	10	160	.400
8484-T	Closed	N/O	A	.150	10	160	.400
8484-TWG	Closed	N/O	A	.150	10	160	.400
185-12	Open	N/C	B	.140	5	175	.250
185-12WG	Open	N/C	B	.140	5	175	.250
189-12	Open	N/C	B	.140	5	175	.250
189-12WG	Open	N/C	B	.140	5	175	.250
8585-T	Open	N/C	B	.140	5	175	.250
8585-TWG	Open	N/C	B	.140	5	175	.250
8989-T	Open	N/C	B	.140	5	175	.250
8989-TWG	Open	N/C	B	.140	5	175	.250
190-12	Open/Closed	SPDT	C	.140	5	175	.250
190-12WG	Open/Closed	SPDT	C	.140	5	175	.250
194-12	Open/Closed	SPDT	C	.140	5	175	.250
194-12WG	Open/Closed	SPDT	C	.140	5	175	.250
195-12		DPDT	Cx2	.140	5	175	.250
195-12WG		DPDT	Cx2	.140	5	175	.250
199-12		DPDT	Cx2	.140	5	175	.250
199-12WG		DPDT	Cx2	.140	5	175	.250

WARRANTY: Lifetime warranty against workmanship, material and factory defects.

GEORGE RISK INDUSTRIES, INC.
G.R.I. PLAZA
KIMBALL, NE 69145



1-800-445-5218
1-800-523-1227
(308) 235-4645
FAX (308) 235-3561
EMAIL: sales@grisk.com

HID® Signo™ Readers

Models: 20, 40, 20K, 40K, 40T

The signature line of readers from HID

HID Signo™ is the signature line of physical access control readers from HID. The versatility, performance and connected capabilities of HID Signo readers set a new industry benchmark for the most highly adaptable, interoperable and secure approach to electronic access control.

Offering an unparalleled breadth of functionality, HID Signo affords security system installers and administrators a simple and effective approach to secure access control for almost any scenario.

With support for the widest array of credential technologies — past, present and future — HID Signo is the perfect choice for those looking to make the transition to a secure authentication technology.

HID Signo readers transcend the traditional approach to security by being designed to be connected and managed remotely without needing to physically touch each device. This functionality empowers access control systems to dynamically respond as new needs, configurations or threats arise.

POWERFULLY SECURE

- Multi-Layered security to ensure data authenticity and privacy
- EAL5+ Certified Secure Element Hardware
- Native OSDP secure channel capability
- Trusted secure authentication using the SIO data model
- Supports HID® Elite Key™ and HID® Corporate 1000™ Programs

MEET EVERY NEED, ADAPT TO ANY SITUATION

- Go mobile with native Bluetooth and NFC support
- Integrated 125 kHz credential read support for easy migration
- Supports over 15 common credential technologies
- Flush mount terminal block and pigtail wiring options
- Robust outdoor performance with an IP65 rating

MANAGE, UPGRADE AND CONFIGURE

- Easily and securely managed using HID Reader Manager®
- Configure via a mobile device or OSDP
- Update firmware in response to threats
- Personalize by configuring audio visual or keypad settings
- Deactivate legacy credential technology to conclude secure migration

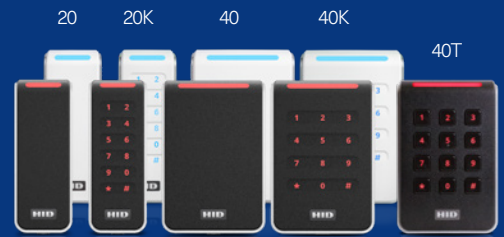

KEY BENEFITS:

- **Highly Versatile** — Support for the widest range of credential technologies, including HID Mobile Access® via native Bluetooth and Near Field Communication (NFC).
- **Enhanced Performance** - Storage of cryptographic keys on certified secure element hardware, plus a new surface detection feature that enables the reader to automatically recalibrate and optimize read range performance.
- **Connected to the Future** — All readers include out-of-the-box support for Open Supervised Device Protocol (OSDP) for secure bidirectional communication.

READY FOR THE FUTURE NOW

- Mobile-ready by default, including Apple's Enhanced Contactless Polling (ECP) to support credentials in Apple Wallet
- Sleek, innovative design to suit modern architecture, available in black or white
- Integrated OSDP for secure authentication and configuration post installation
- Built on a hardware platform designed to be adaptable to support future technology
- Designed to seamlessly integrate into the HID Origo® ecosystem



HID Signo Reader Model	20	20K	40	40K	40T
2.4 GHz (Bluetooth) Credential Compatibility	Mobile Credentials powered by Seos® (HID Mobile Access)				
13.56 MHz (NFC) Credential Compatibility	Seos®, iCLASS SE®, iCLASS SR®, iCLASS®, MIFARE Classic, MIFARE DESFire EV1/EV2/EV3, FeliCa™ & Contactless e-Purse Application Specification (CEPAS), Mobile Credentials powered by Seos (HID Mobile Access)				
125 kHz Credential Compatibility	HID Proximity®, Indala® Proximity, AWID Proximity, and EM Proximity				
Typical Read Range¹	Seos, iCLASS® SE™, iCLASS® SR, iCLASS, MIFARE Classic, MIFARE DESFire EV1/EV2/EV3 & ISO14443A Single Technology Cards – 1.6 to 4 in (4 to 10 cm) ; HID / AWID Proximity®, Indala Proximity®, EM Proximity & 125 kHz Single Technology Cards – 2.4 to 4 in (6 to 10 cm)				
Mounting	Suited for mullion-mount door installations or any flat surface mounting		Suited to mount and cover single gang switch boxes with a slotted mounting plate for alternate back-box spacing		
Color	Black or white with silver trim baseplate				Black with silver trim baseplate ²
Keypad	No	Yes (2 x 6 layout)	No	Yes (3 x 4 layout)	
Dimensions (width x length x depth)	1.77 in x 4.78 in x 0.77 in (45 mm x 121.5 mm x 19.5 mm)	1.78 in x 4.79 in x 0.85 in (45 mm x 121.5 mm x 21.5 mm)	3.15 in x 4.78 in x 0.77 in (80 mm x 121.5 mm x 19.5 mm)	3.16 in x 4.79 in x 0.85 in (80 mm x 121.5 mm x 21.5 mm)	3.16 in x 4.82 in x 0.96 in (80mm x 122.5mm x 24.5mm)
Product Weight	Pigtail: 3.35 oz (95 g) Terminal: 2.65 oz (75 g)	Pigtail: 3.88 oz (110 g) Terminal: 3.17 oz (90 g)	Pigtail: 4.94 oz (140 g) Terminal: 4.23 oz (120 g)	Pigtail: 5.64 oz (160 g) Terminal: 4.94 oz (140 g)	5.82 oz (165g) Terminal Only
Operating Voltage³	12V DC				
Current Draw⁴	NSC ⁵ : 60 mA Peak ⁶ : 250 mA Max. Avg: 70 mA IPM ⁷ : 45 mA	NSC ⁵ : 65 mA Peak ⁶ : 250 mA Max. Avg: 75 mA IPM ⁷ : 48 mA	NSC ⁵ : 65 mA Peak ⁶ : 250 mA Max. Avg: 75 mA IPM ⁷ : 45 mA	NSC ⁵ : 70 mA Peak ⁶ : 250 mA Max. Avg: 80 mA IPM ⁷ : 55 mA	NSC ⁵ : 90mA Peak ⁶ : 250mA Max Avg: 120mA IPM ⁷ : 75mA
Device Input and Output	Input: Tri-color LED, Buzzer, Hold @ Active Low Output: Tamper Relay 0-60V DC @ 100mA Max (Dry Contact)				
Operating Temperature & Humidity	-31° F to +150° F (-35° C to +66° C) 0% to 95% non-condensing				
Storage Temperature	-40° F to +185° F (-40° C to +85° C)				
Environmental Rating	UL294 Outdoor and Indoor rated, IP65				
Transmit Frequency	125 kHz, 13.56 MHz, and 2.4 GHz				
Communications & Panel Connection	Wiegand, Clock-and-Data and RS-485 Half Duplex (OSDP) via Pigtail (18 in / 0.5 m) or Terminal Strip ⁸				
Device Management	HID Reader Manager / OSDP configuration				
Certifications	UL294/cUL (US), FCC (US), IC (Canada), CE (EU), RCM (Australia, New Zealand), SRRC (China), MIC/Giteki (Japan) WPC/BIS (India), KCC (Korea), NCC (Taiwan), iDA (Singapore), MIC (Japan), RoHS, GreenCircle, Bluetooth SIG, and additional regions. www.hidglobal.com/certifications				
Security Ratings	EAL 5+ Certified Secure Element Hardware				
Patents	www.hidglobal.com/patents				
Housing Materials	Polycarbonate – UL94 V0				
UL Reference Number	20	20K	40	40K	40T
Warranty	Limited Lifetime				

- Read range listed is statistical mean rounded to nearest centimeter increment for ID-1 or clamshell credentials. HID Global testing occurs in open air. Form factor, technology and environmental conditions, including metallic mounting surface, can degrade read range performance; plastic spacers are recommended to improve performance on metallic mounting surfaces.
- Black spacers available as an additional accessory at an additional cost.
- Measured in accordance with UL294 standards at +10% and -15% of rated voltage input
- Measured in accordance with UL294 standards; see Installation Guide for details.
- NSC — Normal Standby Current; see Installation Guide for details.
- Peak measures in default condition.
- Intelligent Power Management (IPM) — Reduces reader current consumption up to 43%, based on model, compared to standard operating mode.
- 40T orderable only at Terminal Strip connection type.



hidglobal.com

North America: +1 512 776 9000 | Toll Free: 1 800 237 7769

Europe, Middle East, Africa: +353 91 506 900

Asia Pacific: +852 3160 9800 | Latin America: +52 55 9171 1108

[For more global phone numbers click here](#)

Miami Dade County Department of Regulatory and Economic Resources - Job Copy

3225016727 - 7/29/2025 3:14:23 PM

COMBINED CUT SHEET.pdf

DS160 Series High Performance Request-to-exit Detectors



- ▶ Door monitor with sounder alert
- ▶ Sequential Logic Input (SLI)
- ▶ Internal vertical pointability
- ▶ Wrap-around coverage pattern with precise pattern control
- ▶ Up to 64 second adjustable latch time
- ▶ Selectable relay trigger mode
- ▶ Selectable fail safe/fail secure modes
- ▶ Adjustable sounder volume
- ▶ Activation LED

The DS160 Series consists of the DS160 Detector (light gray) and the DS161 Detector (black) specifically designed for Request-to-exit (REX) applications. With features such as timers, door monitor with sounder alert, and pointable coverage, the DS160 and DS161 have the flexibility to meet the most stringent REX requirements. The exclusive Sequential Logic Input (SLI) provides added security that is not offered in any other REX device.

System overview

Functions

Sequential Logic Input (SLI)

The SLI terminal allows connection of a second device to require sequential detection. This eliminates the possibility that an object that is slid through the door or underneath the door will activate the detector. This input can also be used to lock the sensor if motion is present outside the premises.

Door Monitor

The sensor can monitor a door contact to allow special control of the internal relay. For example, if the door is opened within the relay time period, the sensor can be programmed to halt the timer. If the door is not opened within a specific time period, the relay can be programmed to deactivate.

Sounder Alert

An integrated sounder can be programmed to activate if the door is left open too long. The sounder volume is fully adjustable to 85 dB.

Keycard Input

The keycard input allows the sensor relay to be controlled from an external source, such as an access control system or card reader.

Regulatory information

Europe Complies with EN50131-1 Grade 2

Region	Regulatory compliance/quality marks	
Europe	CE	
USA	UL	ALVY: Access Control Systems Units (UL294) [DS160, DS161]
Australia	RCM	[DS160]

Installation/configuration notes

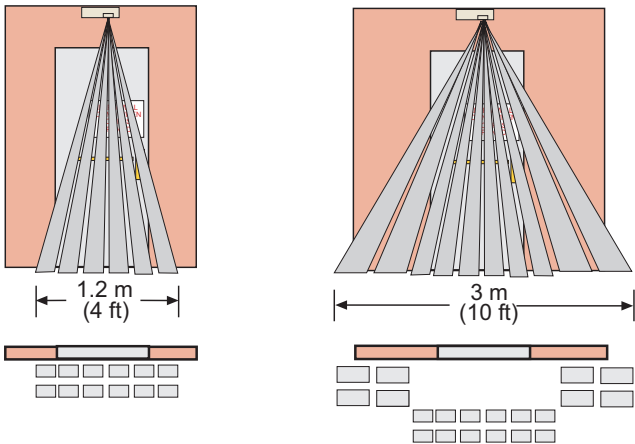

Front View
 Mounted on wall above door and mounted on ceiling .75 m (2.5 ft) in front of the door.

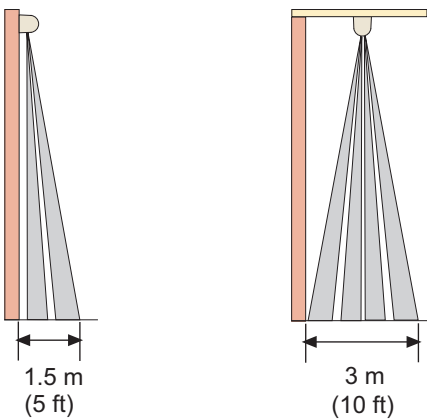

Side View
 The higher that you mount the unit, the larger the coverage area. Do not mount the DS160/DS161 more than 4.6 m (15 ft) above the floor.
 Side view of coverage pattern with the unit mounted at 4.6 m (15 ft) above the floor with the lens pointed straight down.

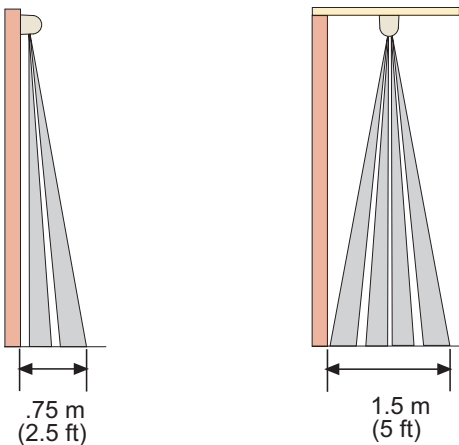

Side View
 The higher that you mount the unit, the larger the coverage area. Do not mount the DS160/DS161 more than 4.6 m (15 ft) above the floor.

Side view of coverage pattern with the unit mounted at 4.6 m (15 ft) above the floor with the lens pointed straight down.

Coverage Information

The coverage (detection area) varies depending on the mounting height above the floor, angle of the lens, and whether the unit is mounted on a wall above the door or on the ceiling. The coverage is 2.4 m x 3 m (8 ft x 10 ft) The coverage patterns for the detector at a height of 2.3 m (7.5 ft) are shown. The coverage pattern increases or decreases with height and detector alignment.

Notice

When you mount the unit on the wall and the lens points straight down, some detection zones point toward the wall and do not detect movement.

The diagrams depict views of the coverage pattern with the detector mounted at 2.3 m (7.5 ft) above the floor with the lens pointed straight down. Zones that are pointed toward the wall are not shown.

Parts included

Technical specifications

Environmental

Operating Temperature:	-29°C to +49°C (-20°F to +120°F) For UL Certificated installations, 0°C to +49°C (+32°F to +120°F)
Radio Frequency Interference (RFI) Immunity:	No alarm or setup on critical frequencies in the range from 26 MHz to 1000 MHz at 50 V/m

Complies with Environmental Class II (EN50130-5)

Mechanical

Dimensions:	4.5 cm x 17.1cm x 4.4 cm (1.80 in. x 6.75 in. x 1.75 in.)
Material:	High impact ABS plastic enclosure

Modes

Power Loss Default:	Programmable fail-safe or fail-secure modes.
Timer:	Programmable reset accumulative or non-reset counting mode.

Electrical

Current Draw:	8 mA nominal standby current, 39 mA at 12 VDC in alarm
---------------	--

Voltage:	12 VAC or VDC to 30 VAC or VDC
Alarm Output:	Two Form C relay contacts each rated 1 A at 30 VAC or VDC for resistive loads
Indicators:	1 activation LED
Relay Latch Time:	Adjustable from 0.5 sec to 64 sec.

Ordering information

DS160 Request-to-exit sensor, sounder

For use in request-to-exit (REX) applications. Provides PIR 2.4 m x 3 m (8 ft x 10 ft) coverage, timers, door monitor with sounder alert, and pointable coverage.
Order number **DS160 | 4.998.800.238 F.01U.364.868 F.01U.405.131**

DS161 Request-to-exit sensor, black, sounder

Black enclosure. For use in Request-to-Exit (REX) applications. Provides PIR, 2.4 m x 3 m (8 ft x 10 ft) coverage, timers, door monitor with sounder alert, and pointable coverage.
Order number **DS161 | 4.998.800.239 F.01U.364.869 F.01U.405.132**

Accessories

TP160 Trim plate for DS150 and DS160

A light gray trim plate used when mounting the detector over a standard single-gang box.
Order number **TP160 | 4.998.800.318**

TP161 Trim plate for DS151 and DS161, black

A black trim plate used when mounting the sensor over a standard single-gang box.
Order number **TP161 | 4.998.130.552**

Represented by:

Europe, Middle East, Africa:
Bosch Security Systems B.V.
P.O. Box 80002
5600 JB Eindhoven, The Netherlands
www.boschsecurity.com/xc/en/contact/
www.boschsecurity.com

Germany:
Bosch Sicherheitssysteme GmbH
Robert-Bosch-Platz 1
D-70839 Gerlingen
www.boschsecurity.com

North America:
Bosch Security Systems, LLC
130 Perinton Parkway
Fairport, New York, 14450, USA
www.boschsecurity.com

Asia-Pacific:
Robert Bosch (SEA) Pte Ltd, Security Systems
11 Bishan Street 21
Singapore 573943
www.boschsecurity.com/xc/en/contact/
www.boschsecurity.com

PRO4200

Professional Series Access Modules

The PRO4200 professional series family of access control modules is designed for high density installations.

The PRO4200 professional series can be managed through WIN-PAK® integrated security suite for more advanced features such as Video integration, advance reporting, rules and photo badging, elevator control, touch-less access and mobile credential management.

Supporting up to 18 doors per enclosure and 34 doors per intelligent controller along with up to 100,000 card capacity, PRO4200 Series provide a combination of small installation footprint and superior cost per door ratio.

The new PRO42IC Intelligent Controller provides I/O support for 2 Doors*. The PRO42R1 provides I/O support for one card access reader, while the PRO42R2 support two card access readers. Both interface with the intelligent control module (PRO42IC). In the event that communication to the intelligent control module is lost, the card access readers be individually configured to allow entrance based on security needs. This customization allow or a be configured as secured, locked and unlocked. PRO4200 modules provide latest bi-directional and strong encrypted OSDP communication with the Access Control readers. For legacy and retrofit installations, Wiegand format is still supported.

The PRO42OUT interfaces provide up to 16, Form C, 30 VDC, 2A relay output controls depending if the board is rack or tile-mounted, power fail and panel tamper when tile mounted. Relays may be used for elevator control, status annunciation and for general facility control, such as door monitoring.



The PRO42IN interfaces provide 16 supervised alarm inputs and a dedicated power fail and panel tamper when tile mounted. An analog to digital converter samples the input values and the digitized result is filtered and processed. Filter parameters are configurable for each input point, resulting in the ability to specify a custom End-Of-Line (EOL) resistance value, sensitivity range and timing parameter.

The PRO4200 Series of access modules are designed to accommodate various mounting options. Units can be mounted in a rack configuration (PRO22ENC1, PRO22ENC2 and PRO22ENC5) when space is limited, or in a tile-mount configuration (PRO22ENC3).

- The PRO22ENC1 is a wall-mounted enclosure rack unit (See picture)
- The PRO22ENC2 is a 19" rack-mounted enclosure rack unit
- The PRO22ENC5 is a rack unit which fits inside a customer's enclosure

* The new PRO42IC Intelligent Controller provides I/O support for up to 2 doors with a maximum of 2 OSDP readers per door or 1 Wiegand reader per door. The PRO42R1 provides I/O support for up to 1 door and the PRO42R2 supports up to 2 doors. The PRO42R1 and PRO42R2 will support a maximum of 2 OSDP readers per door or 1 Wiegand reader per door.

FEATURES AND BENEFITS



- Modular design fits a wide variety of applications
- Up to 9 modules, power-supply and battery can be accommodated by the PRO22ENC1, PRO22ENC2 and PRO22ENC5 (no battery) enclosures
- User programmable relay outputs allow for specific control needs



- RS485 communication to all modules
- Analog to digital converter technology provides digital filtering and input conditioning
- Dedicated cabinet tamper and power monitor inputs
- Supports the choice of normally open, normally closed, supervised, and non-supervised circuits



- System off-line modes customizable per reader include secured access, locked (no access), and unlocked (full-access)
- Supports multiple reader and card formats for maximum flexibility and security options
- Operating modes includes locked, unlocked, secure access, card only, card and PIN, card or PIN and PIN only



- Any combination of 16 downstream I/O or readers modules may be connected to the PRO42IC RS485 ports. 4,000 ft (1,250 m) total bus length per port
- Supports over 50,000 transaction buffer



SPECIFICATIONS

MODULE SPECIFICATIONS	PRO4200 SERIES SINGLE READER MODULE (PRO42R1)	PRO4200 SERIES DUAL READER MODULE (PRO42R2)
PORT	Reader port 12/24VDC @ 500mA, OSDP; Wiegand; Dt/Clk*	2 Reader port 12/24VDC @ 300mA, OSDP; Wiegand; Dt/Clk*
KEYPAD	Keypad multiplexed with card data	
WIRE SUPPORT	Two-wire or one-wire bi-color LED support	
BUZZER SUPPORT	Buzzer support only with one-wire LED control	
ALARM INPUTS	2 supervised, general purpose alarm inputs with programmable circuit type	8 supervised, general purpose alarm inputs with programmable circuit type (only 6 supervised inputs available when using PRO22ENC1, PRO22ENC2 and PRO-22ENC5 enclosures)
OUTPUT RELAYS (DOOR STRIKE(S))	1 output relay, form C, 5A 40 VDC	2 output relay, form C, 2A 30 VDC
OUTPUT RELAYS	1 general purpose output relay, form C, 5A 30 VDC	2 general purpose output relay, form C, 5A 30 VDC
MOUNTING	Designed to be tile-mounted using the PRO22ENC4 enclosure	N/A

ALARM INPUT PROPERTIES

INPUTS	Inputs may be assigned to door related functions or general purpose I/O
CIRCUIT TYPE	Circuit type - normally open, normally closed, non-supervised, supervised (with standard 1K or custom end-of-line resistance 200-10K)
LINE CONDITIONING	Line conditioning - programmable sensitive hold time

OUTPUT CONTROL PROPERTIES

OUTPUTS	Outputs may be assigned to door related functions or general purpose I/O
RELAY RATING	The relay(s) are rated to handle the inductive loads of door locking devices S-4 SUPPRESSOR CABLE TO THE DOOR OPENER
CONFIGURABLE	Configurable as standard (energize to activate) or fail-safe (de-energize to activate)
PULSE TIME	1-42,400 seconds, 1-255 for door relays
RS485 PORT	RS485 port, 4,000 ft (1,250m) total bus length
STANDARD SPEED	38.4 Kbps

MODULE SPECIFICATIONS	PRO4200 SERIES SIXTEEN RELAY OUTPUT MODULE (PRO42OUT)	PRO4200 SERIES SIXTEEN ALARM INPUT MODULE (PRO42IN)
-----------------------	---	---

ALARM INPUTS	2 dedicated (unsupervised) alarm inputs for tamper detection and power loss (tile-mounted only)	
ALARM INPUTS	N/A	16 general purpose inputs with programmable circuit type
OUTPUT RELAYS	12 general purpose output relays, form C, 5A 30 VDC (16 are available when using PRO22ENC3 tile-mounted enclosure)	2 general purpose, form C, 5A 30 VDC relays (only one available when using PRO22ENC1, PRO22ENC2 and PRO22ENC5)

OUTPUT CONTROL PROPERTIES

OUTPUT	All 16-relay outputs in the tile-mount configuration (1 rack mount) are available for general purpose I/O	Both relay outputs are available for general purpose I/O
DRY CIRCUIT LOGIC	The 5A relays are rated to handle dry circuit logic (Resistive)	Both relay outputs are rated to handle dry circuit logic (Resistive)
PULSE TIME	1-32,400 seconds	
CONFIGURABLE	Configurable as standard (energize to activate) or fail-safe (de-energize to activate)	N/A

ALARM INPUT PROPERTIES

INPUTS	2 dedicated for tamper detection and power loss	All 16 inputs may be assigned to door related functions or general purpose I/O 2 dedicated for tamper and power loss
CIRCUIT TYPE	N/A	Circuit type - normally open, normally closed, non-supervised, supervised (with correct EOL)
LINE CONDITIONING	N/A	Line conditioning - programmable sensitivity and hold time

COMMUNICATION FEATURES

MEASUREMENTS	RS485 port, 4,000 ft (1,250m) total bus length per port
---------------------	---

BENEFITS

- Anti-passback support - free pass and exempt flags, last area accessed, last reader accessed and time/date of last access
- Modular hardware architecture provides flexibility and expansion capabilities
- Large, local controller database allows access control decisions to be made by controller in real time without the need to communicate to the server
- ADA compliant allowing expanded door times selectable per reader
- Scalable architecture ensures optimal performance with a seamless upgrade path to accommodate future growth beyond its initial installation
- Four-state alarm input circuits - normally opened, normally closed, non-supervised, supervised (w/EOL)
- Rack or tile mounting options available
- Alarm conditioning with programmable sensitivity and hold time
- Selectable reader states include card and PIN, card or PIN, card only, or PIN only
- Power Supply supports 120 or 230 VAC
- System off-line modes customizable per reader include secured access, locked (no access), and unlocked (full-access)
- Supports multiple reader and card formats for maximum flexibility and security options
- Supports Wiegand and/or OSDP communication
- Enhanced Cyber Security
- Port based network access control using 802.1X
- Host communications protected by TLS 1.2/1.1 or AES-256/128

PRO4200 CONFIGURATION

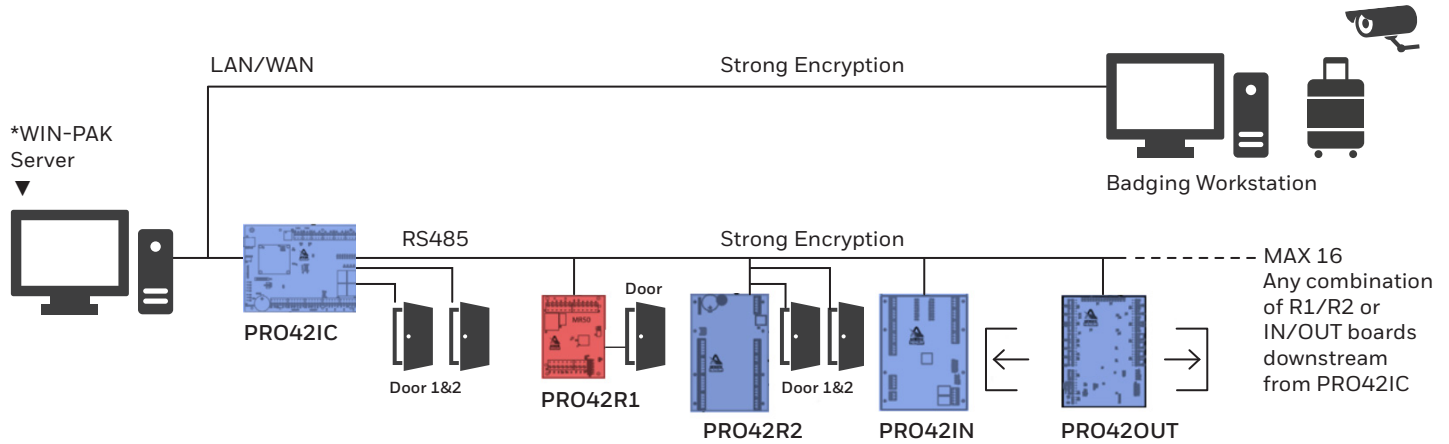

RED boards = Mercury Series 3

BLUE boards = Honeywell PRO4200 modules

*WIN-PAK 4.8.2 or higher supports Legacy Mode which includes all feature sets of the PRO3200 Series.

*Native support in WIN-PAK coming soon (PRO42IC On-Board Door support, OSDPV2, TLS1.2).

MODULE	READERS	PRO22ENC1		PRO22ENC3	
		INPUTS	OUTPUTS	INPUTS	OUTPUTS
PRO42R1	2 OSDP 1 Wiegand	N/A	N/A	2	2
PRO42R2	4 OSDP 2 Wiegand	6	4	10**	6
PRO42OUT	0	0	12	2**	16
PRO42IN	0	16	1	18**	2

****Two are used to monitor Power and Tamper (Dedicated)**

PRO22ENC1 = 9 Board Capacity/PRO22ENC3 = 2 Board Capacity



SPECIFICATIONS

DIMENSIONS / BOARDS

- **PRO42R1**
2.75" H x 4.25" W x 1.0" D
(70mm x 108mm x 25mm)
- **PRO42IC, PRO42R2; PRO42IN;
PRO42OUT**
9.0" H x 5.5" W x 1.0" D
(230mm x 140mm x 25mm)

ENCLOSURES

- **PRO22ENC1**
13.9" H x 17" W x 9" D
(353 mm x 432mm x 229 mm)
- **PRO22ENC2**
13.9" H x 18.9" W x 9" D
(353 mm x 480 mm x 229 mm)
- **PRO22ENC3**
14" H x 16" W x 4" D
(356 mm x 406 mm x 102 mm)
- **PRO22ENC4**
8.37" H x 7.63" W x 7.63 D
(213 mm x 194 mm x 194 mm)
- **PRO22ENC5**
9.35" H x 16.85" W x 5.6" D
(237 mm x 428 mm x 142 mm)

ENVIRONMENT

- Temperature: 0°C to 49°C* operational;
-55°C to 85°C storage
- Humidity: 5 to 85% RHNC

WIRE REQUIREMENTS

- **Power**
twisted pair, 18 AWG
- **Ethernet**
F(S)TP/CAT7, 300 ft (100m) max
- **RS485**
22- 24 AWG, 4,000 ft (1,200m) max, two
twisted pairs with shield (F(S)TP/CAT7)
- **Alarm Input**
twisted pair, 30 ohms max

ENCLOSURES

- **PRO22ENC1**
(Wall-mount) Capacity: 9 modules.
Power supply and battery not included
- **PRO22ENC2**
(19" Rack-mount) Capacity: 9 modules.
Power supply and battery not included
- **PRO22ENC3**
(Tile-mount) Capacity: 2 modules. Power
supply and battery included
- **PRO22ENC4**
(Tile-mount) Capacity: 1 module
(PRO42R1 only). Power supply and
battery included
- **PRO22ENC5**
(Cage only for custom enclosures)
Capacity: 9 modules. Power supply and
battery not included

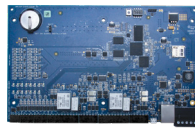

PRO42IC



PRO42R2

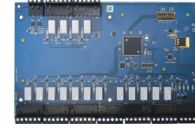

PRO42OUT



PRO42IN

PRO4200 CONTROLLERS

PRO42IC	PRO4200 Intelligent Controller
PRO42R1	PRO4200 single reader module
PRO42R2	PRO4200 Dual Reader Module
PRO42OUT	PRO4200 16 Relay Output Module
PRO42IN	PRO4200 16 Alarm Input Module

PRO-SERIES ENCLOSURES

PRO22ENC1	(Wall-mount) Capacity: 9 modules. Power supply and battery not included
PRO22ENC2	(19" Rack-mount) Capacity: 9 modules. Power supply and battery not included
PRO22ENC3	(Tile Mount) Capacity: 2 modules. Power supply and battery included
PRO22ENC4	(Tile-mount) Capacity: 2 modules.(PRO42R2 only). Power supply and battery not included
PRO22ENC5	(Cage only for custom enclosures) Capacity: 9 modules. Power supply and battery not included

PRO4200 STARTER KIT WITH SOFTWARE

PRO42SKD10*	10 Door Starter Kit (1) PRO42E1D8 with WIN-PAK SE Software
--------------------	--

* Coming soon

PRO4200 EXPANSION KITS

PRO4E1D4*	Door Kit: (1) PRO42R2, (2) S-4, and (1) PRO42E1EN
PRO4E1D6*	6 Door Kit: (2) PRO42R2, (4) S-4, and (1) PRO42E1EN
PRO4E1D10*	10 Door Kit: (4) PRO42R2, (8) S-4, and (1) PRO42E1EN

OPTIONAL ACCESSORIES

PRO22DCC	Daisy Chain cable required for PRO22ENC1, PRO22ENC2 and PRO22ENC5
PRO42PSU120	Rack-mounted power supply for PRO22ENC1, PRO22ENC2 and PRO22ENC5. Requires PRO22BAT1
PRO22BAT1	Battery, 7AH 12V

NETWORK KITS

PRO42E1EN	Includes: PRO22ENC1, PRO42IC, PRO42PSU120, PRO22BAT1 and PRO22DCC
PRO42E2EN	Includes: PRO22ENC2, PRO42IC, PRO42PSU120, PRO22BAT1 and PRO22DCC

Honeywell Commercial Security

715 Peachtree Street NE

Atlanta, GA 30308

322501672734578/29/2025 3:14:23 PM

COMBINED CUT SHEET_V2.pdf

www.honeywell.com

Examiner

Date Time Stamp

Trade Stamp Name

CARTER, THOMAS J. 7/29/2025 3:06:16 PM FIRE Reference Only.

HSI-PRO42-02-US(1220)DS-C
© 2020 Honeywell International Inc.

THE
FUTURE
IS
WHAT
WE
MAKE IT

Honeywell



AL600ULACM

Overview

AL600ULACM converts a 115VAC 60Hz input into eight (8) independently controlled 12VDC or 24VDC Fail-Safe and/or Fail-Secure outputs with a total of 6 amp continuous supply current. These power outputs can be converted to dry form “C” contacts. Outputs are activated by an open collector sink or normally open (NO) dry trigger input from an Access Control System, Card Reader, Keypad, Push Button, PIR, etc. This unit will route power to a variety of access control hardware devices including Mag Locks, Electric Strikes, Magnetic Door Holders, etc. The outputs will operate in both Fail-Safe and/or Fail-Secure modes. This unit is designed to be powered by one common power source (factory installed) which will provide power for both the board operation and locking devices, or two (2) totally independent power sources, one (1) providing power for board operation and the other for lock / accessory power. The FACP Interface enables Emergency Egress, Alarm Monitoring, or may be used to trigger other auxiliary devices. The fire alarm disconnect feature is individually selectable for any or all of the eight (8) outputs.

Specifications

Input:

- Input 115VAC 60Hz rated @ 3.5 amp.
- Power supply input options:
 - a) One (1) common power input for ACM8 and lock power (factory installed).
 - b) Two (2) isolated power inputs - One (1) to power the ACM8 and one (1) for lock accessory power, (external power supply is required). Current is determined by the power supply connected, not to exceed a maximum of 10 amp total.
- Eight (8) Access Control System trigger inputs.

Input options:

 - a) Eight (8) normally open (NO) inputs.
 - b) Eight (8) open collector inputs.
 - c) Any combination of the above.

Output:

- 12VDC or 24VDC @ 6 amp supply current.
- Eight (8) independently controlled outputs.

Output options:

 - a) Eight (8) Fail-Safe and/or Fail-Secure power outputs.
 - b) Eight (8) form “C” 5 amp rated relay outputs
 - c) Any combination of the above.
- Eight (8) auxiliary power outputs (unswitched)
- Output ratings:
 - Fuses are rated @ 3.5 amp.
- Filtered and electronically regulated outputs (built-in power supply).

Supervision:

- AC fail supervision (form “C” contacts).
 - Notification trigger is selectable for 30 seconds (factory set) or 6 hours.
- Low battery and battery presence supervision (form “C” contact).

Features:

- Fire Alarm disconnect (latching or non-latching) is individually selectable for any or all of the eight (8) outputs.
- Fire Alarm disconnect input options:
 - a) Normally open (NO) or normally closed (NC) dry contact input.
 - b) Polarity reversal input from FACP signaling circuit.
- Alarm output relay indicates that FACP input is triggered (form “C” contact rated @ 1 amp 28VDC).
- Short circuit and thermal overload protection.

Visual Indicators:

- Red LEDs indicate outputs are triggered (relays energized).
- Green LED indicates FACP disconnect is triggered.
- AC input and DC output LED indicators.

Battery Backup:

- Built-in charger for sealed lead acid or gel type batteries.
- Power Supply Board maximum charge current 0.7 amp.
- Automatic switch over to stand-by battery when AC fails.
- Zero voltage drop when unit switches over to battery backup (AC failure condition).

Electrical:

- Operating temperature: 0° C to 49° C ambient.
- ACM8 board main fuse is rated at 10 amp.
- BTU/Hr.:
 - 12VDC: 36.85 BTU/Hr.
 - 24VDC: 73.70 BTU/Hr.

Mechanical:

- Enclosure Dimensions (L x W x H approx.): 15.5” x 12” x 4.5” (393.7mm x 304.8mm x 114.3mm).
- Enclosure accommodates up to two (2) 12AH batteries.
- Product weight (approx.): 10.3 lbs. (4.67 kg).
- Shipping weight (approx.): 12.0 lbs. (5.26 kg).

Agency Approvals

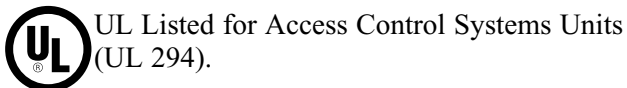

MEA MEA - NYC Department of Buildings Approved.

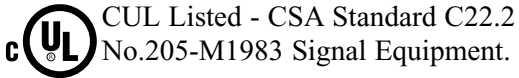

Enclosure Dimensions (H x W x D approximate):

15.5" x 12" x 4.5" (393.7mm x 304.8mm x 114.3mm)

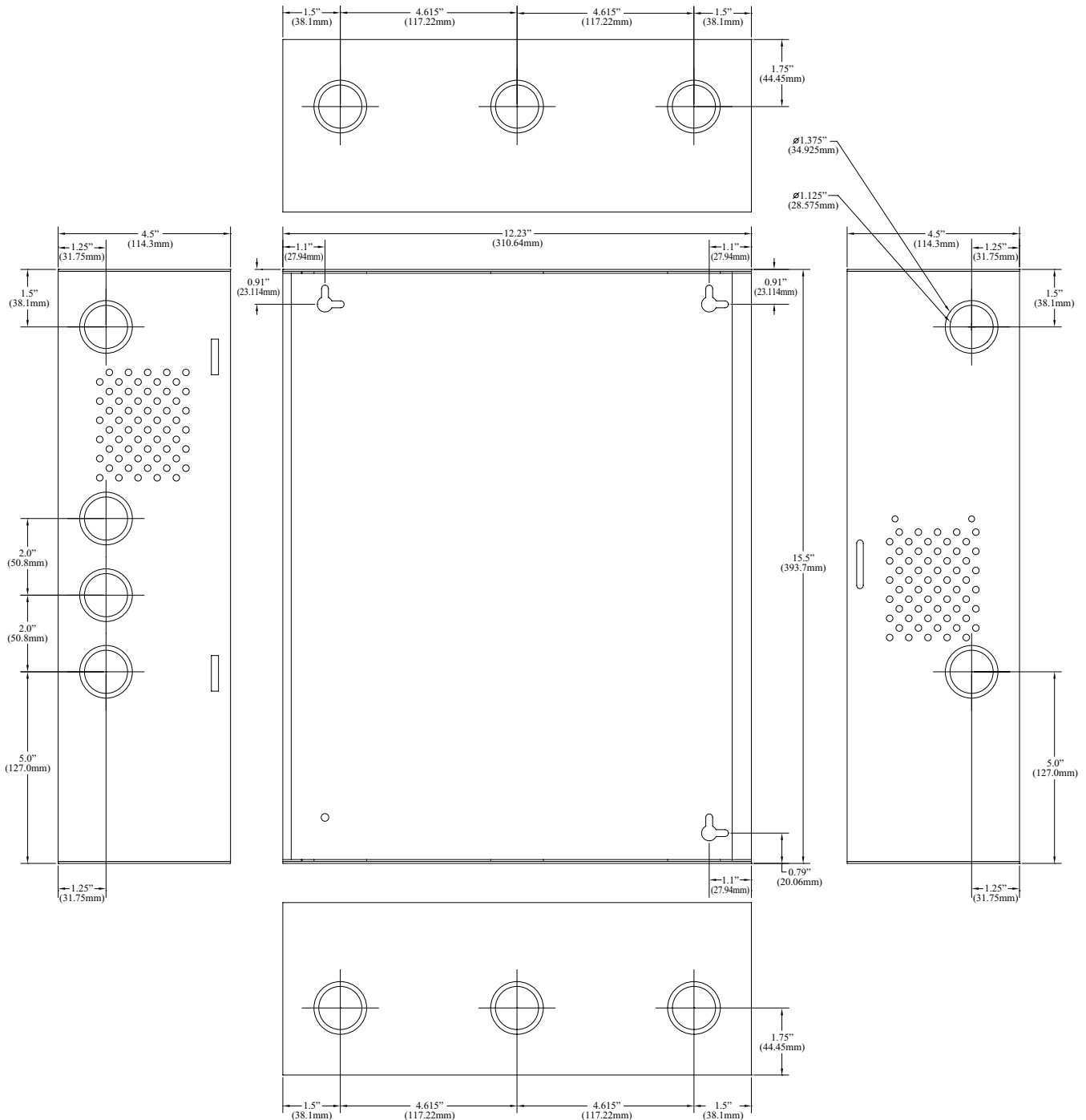

HES[®] 8000 Series No-Cut Electric Strikes

Retrofit solutions to electrify
cylindrical and mortise locksets

ELECTRONIC SECURITY HARDWARE HES PRODUCTS

Experience a safer
and more open world

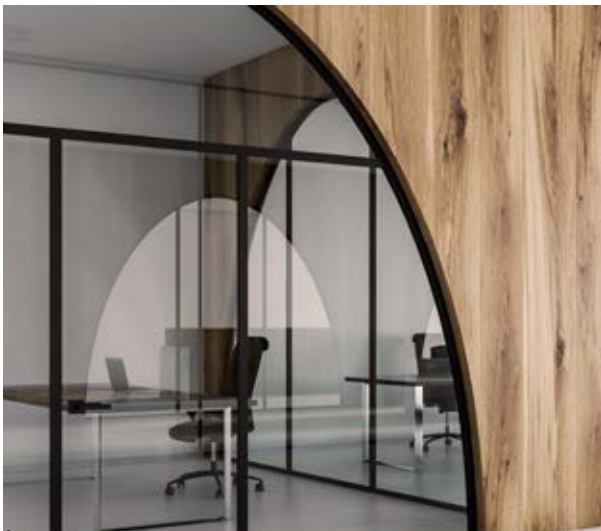

The HES 8000 Series offers compact, high performance electric strikes featuring a unique concealed design for cylindrical or mortise locksets.

No cutting on the frame is required, which means less time spent installing the strike. Simply remove the existing strike plate, adjust the vertical alignment to the latchbolt centerline, and install.

Ideal for aluminum, wood and hollow metal applications in office spaces, interior entries, stairwells, and other openings requiring electronic access control.



HES 8000

Works with Cylindrical Locksets up to a 5/8" Throw Latchbolt



Cylindrical Locksets

Concealed Design

- Fits in standard ANSI prep
- Completely concealed in frame
- Available in seven finishes



HES 8000

Works with Cylindrical Locksets up to a 5/8" Throw Latchbolt



Cylindrical Locksets



Fire Rated



HES 8000

Works with Mortise Locksets without a Deadbolt up to 3/4" Throw Latchbolt
Full pocket shims for horizontal adjustment



Mortise Locks without Deadbolt



Fire Rated

Saves Time

- No cutting in to the face of the frame
- Accommodates doors sag with patented vertical adjustability



Specifications for all HES 8000 Family Strikes

Certifications

- ANSI/BHMA, A156.31 Grade 1
- UL 1034 burglary-resistant listed and suitable for outdoor use
- **UL 294 listed**
- RoHS Compliant

Electrical (DC Continuous Duty)

- Dual voltage 12/24 VDC
- 240 mA at 12VDC/120 mA at 24 VDC

Features

- No cutting required
- Vertical adjustability to accommodate door sag and misalignment
- Tamper resistant
- Non-handed
- Internally mounted solenoid
- SecuriCare five-year, no-fault, no questions asked warranty
- Addition of HES SMART Pac® III extends warranty to 10 years



		HES 8000	HES 8300	HES 8500	COMPETITOR
FRAME APPLICATION	Hollow Metal	✓	✓	✓	✓
	Wood	✓	✓		✓
	Aluminum	✓	✓		
	No-Cut	✓	✓	✓	✓
	Vertical adjustment	✓	✓		
	Horizontal Adjustment			✓	
	Cylindrical Locksets	✓	✓		✓
HOLDING FORCE	Mortise Locksets			✓	
	Static Strength 1,500 lbs	✓	✓	✓	✓
ELECTRICAL	Dynamic Strength 70 ft-lbs	✓	✓	✓	✓
	12 VDC Current Draw	240mA	240mA	240mA	300mA
	24 VDC Current Draw	120mA	240mA	240mA	150mA
	Dual Voltage 12/24 VDC Continuous Duty	✓	✓	✓	✓
	Field Selectable (Fail Secure/Fail Safe)	✓	✓	✓	✓
SPECIFICATIONS	UL1034 Burglary Resistant Listed (Indoor)	✓	✓	✓	
	UL1034 Burglary Resistant Listed (Outdoor)	✓	✓	✓	
	UL 294 Listed	✓	✓	✓	
	UL 10C Fire rated – Class A, 3 Hour Single Door		✓	✓	
	RoHS Compliant	✓	✓	✓	
	Cycle Testing	1M	1M	1M	250,000
	Finish Options	7	7	7	1
	Monitoring Type	Latchbolt Status Only	Latchbolt Status Only	Latchbolt & Strike Status	Latchbolt Only
Warranty	Five-year no questions asked	Five-year no questions asked	Five-year no questions asked	One-year limited	



Grade 1



SecuriCare Warranty



Field Selectable (Fail secure /Fail safe)



Dual Voltage 12/24



PoE Friendly



Outdoor Rated



Miami Dade County Department of Regulatory and Economic Resources - Job Copy
 3225016727 - 7/29/2025 3:14:23 PM
 COMBINED CUT SHEET_V2.pdf

Examiner: CARTER, THOMAS J. Date Time Stamp: 7/29/2025 3:06:16 PM Trade Stamp Name: FIRE Reference Only.

The ASSA ABLOY Group is the global leader in access solutions. Every day, we help billions of people experience a more open world.

ASSA ABLOY Opening Solutions leads the development within door openings and products for access solutions in homes, businesses and institutions. Our offering includes doors, frames, door and window hardware, locks, perimeter fencing, access control and service.



How to Order

Series	Model	Finish*	Option (s)
8000	—	— 630	— LBM
8000	C* Complete Electric Strike; Includes the 801 and 801A faceplates	605 Bright Brass	LBM Latchbolt Monitor
8300		606 Satin Brass	
		612 Satin Bronze	
		613 Bronze Toned	
		629 Bright Stainless Steel	
		630 Satin Stainless Steel	
BLK Black			
8500		605 Bright Brass	LBM Latchbolt Monitor
		606 Satin Brass	
		612 Satin Bronze	LBSM Latchbolt & Strike Monitor
		613 Bronze Toned	
		629 Bright Stainless Steel	
630 Satin Stainless Steel			

*Complete Pacs are only available in the 630 finish

ELECTRONIC SECURITY HARDWARE

HES | Securitron

USA

800 626 7590 | assaabloyesh.com

customerservice.esh@assaabloy.com | techsupport.esh@assaabloy.com | orders.esh@assaabloy.com

CANADA

800 461 3007 | assaabloydss.ca

sales.dss.ca@assaabloy.com | orders.dss.ca@assaabloy.com

Connect with ASSA ABLOY Electronic Security Hardware

  @assaabloyesh   ASSA ABLOY Electronic Security Hardware

Miami Dade County Department of Regulatory and Economic Resources - Job Copy

3225016727 - 7/29/2025 3:14:23 PM
Patent pending and/or patent www.assaabloydss.com/patents
COMBINED CUT SHEET_V2.pdf

Examiner: 2019, Hanchett Entry Date, Time Stamp, Trade Stamp, Name, Title, Invention in whole
CARTER, THOMAS J. 7/29/2025 3:06:16 PM, FIRE, Reference Only.

3/4" & 1" Steel Door Recessed Switch Set

WWW.GRISK.COM



180 / 184 / 8080-T Series



- ◆ Recessed magnetic contact
- ◆ 12" #22AWG leads or screw terminals
- ◆ Longer leads, zip cord or jacketed cable upon request
- ◆ Built in E.O.L. Resistors and Diodes upon request
 - ◆ Supervisory Loops upon request
 - ◆ Colors white, brown, gray, black
 - ◆  Indicates U.L. 10C Fire Rated



180-12







184-12 CE



8484-T



8080-T

		Part Numbers			
		<u>Closed Loop</u>	<u>Open Loop</u>	<u>SPDT</u>	<u>DPDT</u>
Standard Gap up to 1/2" on steel*	3/4" Dia.	180-12 	185-12	190-12	195-12
	1" Dia.	C € {184-12} 	189-12	194-12	C € {199-12}
	3/4" Dia.	8080-T	8585-T		
	1" Dia.	8484-T	8989-T		
Wide Gap 3/4"+ on steel*	3/4" Dia.	180-12WG 	185-12WG	190-12WG	195-12WG
	1" Dia.	184-12WG 	189-12WG	194-12WG	199-12WG
	3/4" Dia.	8080-TWG	8585-TWG		
	1" Dia.	8484-TWG	8989-TWG		

7/8" Diameter also available. P/N 81-12 & 81-12WG, white or black only. Call the factory for more information.

INSTALLATION APPLICATIONS

The GRI 180-12 is the industry standard 3/4" diameter recessed steel door switch set with 12" leads. The innovative GRI 8080-T series is a 3/4" diameter recessed switch set designed for residential, commercial and industrial doors and frames. The shorter length terminals makes the installation of the set quick and simple.

WARRANTY: Lifetime warranty against workmanship, material and factory defects.

GEORGE RISK INDUSTRIES, INC.

G.R.I. PLAZA
1000 BALLENE NE 69445

Miami Dade County Department of Regulatory and Economic Resources - Job Copy
3225016727 - 7/29/2025 3:14:23 PM

COMBINED CWT SHEET V2.pdf

Examiner Date Time Stamp

Trade Stamp Name

CARTER, THOMAS J. 7/29/2025 3:06:16 PM FIRE Reference Only.



1-800-445-5218

1-800-523-1227

(308) 235-4645

FAX (308) 235-3561

E-MAIL: sales@grisk.com

3/4" & 1" Steel Door Recessed Switch Set

WWW.GRISK.COM

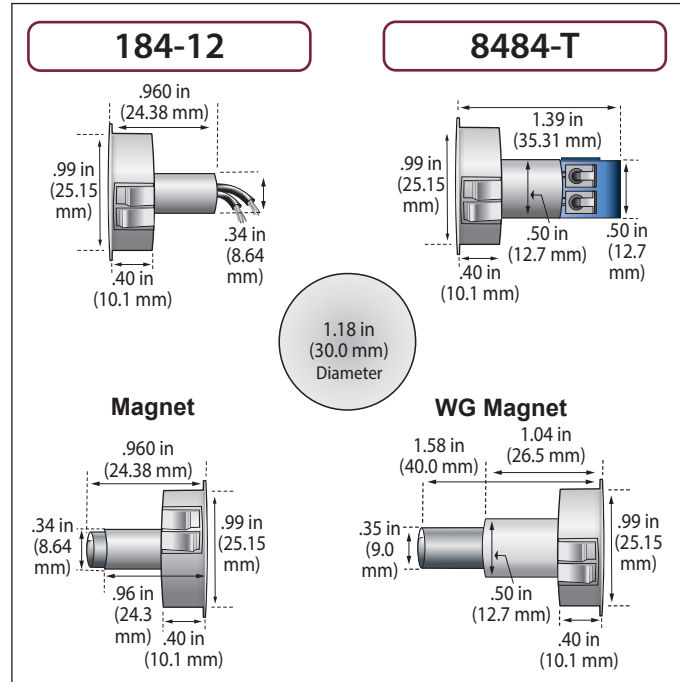
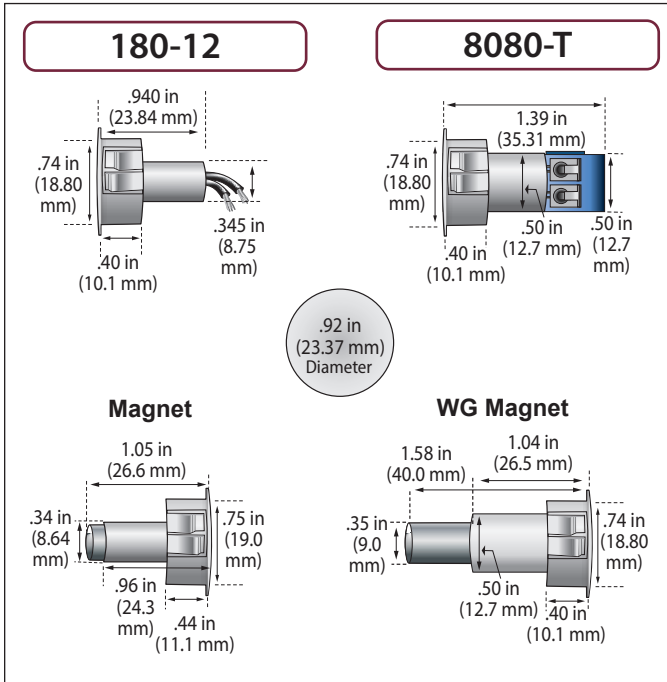

GRI PRODUCTS MEET OR EXCEED THESE MINIMUM GENERAL SPECIFICATIONS:

Part Number	Loop Type	Electrical Configuration	Reed Form	Maximum Initial Contact Resistance (Ω)	Max. Contact Rating (W)	Max. Switching Voltage (VDC)	Max. Switching Current (A)
180-12	Closed	N/O	A	.150	10	200	.400
180-12WG	Closed	N/O	A	.150	10	200	.400
184-12	Closed	N/O	A	.150	10	200	.400
184-12WG	Closed	N/O	A	.150	10	200	.400
8080-T	Closed	N/O	A	.150	10	160	.400
8080-TWG	Closed	N/O	A	.150	10	160	.400
8484-T	Closed	N/O	A	.150	10	160	.400
8484-TWG	Closed	N/O	A	.150	10	160	.400
185-12	Open	N/C	B	.140	5	175	.250
185-12WG	Open	N/C	B	.140	5	175	.250
189-12	Open	N/C	B	.140	5	175	.250
189-12WG	Open	N/C	B	.140	5	175	.250
8585-T	Open	N/C	B	.140	5	175	.250
8585-TWG	Open	N/C	B	.140	5	175	.250
8989-T	Open	N/C	B	.140	5	175	.250
8989-TWG	Open	N/C	B	.140	5	175	.250
190-12	Open/Closed	SPDT	C	.140	5	175	.250
190-12WG	Open/Closed	SPDT	C	.140	5	175	.250
194-12	Open/Closed	SPDT	C	.140	5	175	.250
194-12WG	Open/Closed	SPDT	C	.140	5	175	.250
195-12		DPDT	Cx2	.140	5	175	.250
195-12WG		DPDT	Cx2	.140	5	175	.250
199-12		DPDT	Cx2	.140	5	175	.250
199-12WG		DPDT	Cx2	.140	5	175	.250

WARRANTY: Lifetime warranty against workmanship, material and factory defects.

GEORGE RISK INDUSTRIES, INC.

G.R.I. PLAZA

Miami Dade County Department of Regulatory and Economic Resources - Job Copy

3225016727 - 7/29/2025 3:14:23 PM

COMBINED CUT SHEET V2.pdf

Examiner Date Time Stamp

CARTER, THOMAS J. 7/29/2025 3:06:16 PM



Proudly Made in U.S.A.

Trade Stamp Name

FIRE Reference Only.

1-800-445-5218

1-800-523-1227

(308) 235-4645

FAX (308) 235-3561

E-MAIL: sales@grisk.com

HID® Signo™ Readers

Models: 20, 40, 20K, 40K, 40T

The signature line of readers from HID

HID Signo™ is the signature line of physical access control readers from HID. The versatility, performance and connected capabilities of HID Signo readers set a new industry benchmark for the most highly adaptable, interoperable and secure approach to electronic access control.

Offering an unparalleled breadth of functionality, HID Signo affords security system installers and administrators a simple and effective approach to secure access control for almost any scenario.

With support for the widest array of credential technologies — past, present and future — HID Signo is the perfect choice for those looking to make the transition to a secure authentication technology.

HID Signo readers transcend the traditional approach to security by being designed to be connected and managed remotely without needing to physically touch each device. This functionality empowers access control systems to dynamically respond as new needs, configurations or threats arise.

POWERFULLY SECURE

- Multi-Layered security to ensure data authenticity and privacy
- EAL5+ Certified Secure Element Hardware
- Native OSDP secure channel capability
- Trusted secure authentication using the SIO data model
- Supports HID® Elite Key™ and HID® Corporate 1000™ Programs

MEET EVERY NEED, ADAPT TO ANY SITUATION

- Go mobile with native Bluetooth and NFC support
- Integrated 125 kHz credential read support for easy migration
- Supports over 15 common credential technologies
- Flush mount terminal block and pigtail wiring options
- Robust outdoor performance with an IP65 rating

MANAGE, UPGRADE AND CONFIGURE

- Easily and securely managed using HID Reader Manager®
- Configure via a mobile device or OSDP
- Update firmware in response to threats
- Personalize by configuring audio visual or keypad settings
- Deactivate legacy credential technology to conclude secure migration



KEY BENEFITS:

- **Highly Versatile** — Support for the widest range of credential technologies, including HID Mobile Access® via native Bluetooth and Near Field Communication (NFC).
- **Enhanced Performance** - Storage of cryptographic keys on certified secure element hardware, plus a new surface detection feature that enables the reader to automatically recalibrate and optimize read range performance.
- **Connected to the Future** — All readers include out-of-the-box support for Open Supervised Device Protocol (OSDP) for secure bidirectional communication.

READY FOR THE FUTURE NOW

- Mobile-ready by default, including Apple's Enhanced Contactless Polling (ECP) to support credentials in Apple Wallet
- Sleek, innovative design to suit modern architecture, available in black or white
- Integrated OSDP for secure authentication and configuration post installation
- Built on a hardware platform designed to be adaptable to support future technology
- Designed to seamlessly integrate into the HID Origo® ecosystem

HID Signo Reader Model	20	20K	40	40K	40T
2.4 GHz (Bluetooth) Credential Compatibility	Mobile Credentials powered by Seos® (HID Mobile Access)				
13.56 MHz (NFC) Credential Compatibility	Seos®, iCLASS SE®, iCLASS SR®, iCLASS®, MIFARE Classic, MIFARE DESFire EV1/EV2/EV3, FeliCa™ & Contactless e-Purse Application Specification (CEPAS), Mobile Credentials powered by Seos (HID Mobile Access)				
125 kHz Credential Compatibility	HID Proximity®, Indala® Proximity, AWID Proximity, and EM Proximity				
Typical Read Range¹	Seos, iCLASS® SE™, iCLASS® SR, iCLASS, MIFARE Classic, MIFARE DESFire EV1/EV2/EV3 & ISO14443A Single Technology Cards – 1.6 to 4 in (4 to 10 cm) ; HID / AWID Proximity®, Indala Proximity®, EM Proximity & 125 kHz Single Technology Cards – 2.4 to 4 in (6 to 10 cm)				
Mounting	Suited for mullion-mount door installations or any flat surface mounting		Suited to mount and cover single gang switch boxes with a slotted mounting plate for alternate back-box spacing		
Color	Black or white with silver trim baseplate				Black with silver trim baseplate ²
Keypad	No	Yes (2 x 6 layout)	No	Yes (3 x 4 layout)	
Dimensions (width x length x depth)	1.77 in x 4.78 in x 0.77 in (45 mm x 121.5 mm x 19.5 mm)	1.78 in x 4.79 in x 0.85 in (45 mm x 121.5 mm x 21.5 mm)	3.15 in x 4.78 in x 0.77 in (80 mm x 121.5 mm x 19.5 mm)	3.16 in x 4.79 in x 0.85 in (80 mm x 121.5 mm x 21.5 mm)	3.16 in x 4.82 in x 0.96 in (80mm x 122.5mm x 24.5mm)
Product Weight	Pigtail: 3.35 oz (95 g) Terminal: 2.65 oz (75 g)	Pigtail: 3.88 oz (110 g) Terminal: 3.17 oz (90 g)	Pigtail: 4.94 oz (140 g) Terminal: 4.23 oz (120 g)	Pigtail: 5.64 oz (160 g) Terminal: 4.94 oz (140 g)	5.82 oz (165g) Terminal Only
Operating Voltage³	12V DC				
Current Draw⁴	NSC ⁵ : 60 mA Peak ⁶ : 250 mA Max. Avg: 70 mA IPM ⁷ : 45 mA	NSC ⁵ : 65 mA Peak ⁶ : 250 mA Max. Avg: 75 mA IPM ⁷ : 48 mA	NSC ⁵ : 65 mA Peak ⁶ : 250 mA Max. Avg: 75 mA IPM ⁷ : 45 mA	NSC ⁵ : 70 mA Peak ⁶ : 250 mA Max. Avg: 80 mA IPM ⁷ : 55 mA	NSC ⁵ : 90mA Peak ⁶ : 250mA Max Avg: 120mA IPM ⁷ : 75mA
Device Input and Output	Input: Tri-color LED, Buzzer, Hold @ Active Low Output: Tamper Relay 0-60V DC @ 100mA Max (Dry Contact)				
Operating Temperature & Humidity	-31° F to +150° F (-35° C to +66° C) 0% to 95% non-condensing				
Storage Temperature	-40° F to +185° F (-40° C to +85° C)				
Environmental Rating	UL294 Outdoor and Indoor rated, IP65				
Transmit Frequency	125 kHz, 13.56 MHz, and 2.4 GHz				
Communications & Panel Connection	Wiegand, Clock-and-Data and RS-485 Half Duplex (OSDP) via Pigtail (18 in / 0.5 m) or Terminal Strip ⁸				
Device Management	HID Reader Manager / OSDP configuration				
Certifications	UL294/cUL (US), FCC (US), IC (Canada), CE (EU), RCM (Australia, New Zealand), SRRC (China), MIC/Giteki (Japan) WPC/BIS (India), KCC (Korea), NCC (Taiwan), iDA (Singapore), MIC (Japan), RoHS, GreenCircle, Bluetooth SIG, and additional regions. www.hidglobal.com/certifications				
Security Ratings	EAL 5+ Certified Secure Element Hardware				
Patents	www.hidglobal.com/patents				
Housing Materials	Polycarbonate – UL94 V0				
UL Reference Number	20	20K	40	40K	40T
Warranty	Limited Lifetime				

- 1 Read range listed is statistical mean rounded to nearest centimeter increment for ID-1 or clamshell credentials. HID Global testing occurs in open air. Form factor, technology and environmental conditions, including metallic mounting surface, can degrade read range performance; plastic spacers are recommended to improve performance on metallic mounting surfaces.
- 2 Black spacers available as an additional accessory at an additional cost.
- 3 Measured in accordance with UL294 standards at +10% and -15% of rated voltage input
- 4 Measured in accordance with UL294 standards; see Installation Guide for details.
- 5 NSC — Normal Standby Current; see Installation Guide for details.
- 6 Peak measures in default condition.
- 7 Intelligent Power Management (IPM) — Reduces reader current consumption up to 43%, based on model, compared to standard operating mode.
- 8 40T orderable only at Terminal Strip connection type.



hidglobal.com

North America: +1 512 776 9000 | Toll Free: 1 800 237 7769

Miami, Dade County Department of Regulatory and Economic Resources - Job Copy

3250167277-7/29/2025 3:14:23 PM

COMBINED CUT SHEET V2.pdf

Examiner Date Time Stamp

Trade Stamp Name

CARTER, THOMAS J. 7/29/2025 3:06:16 PM FIRE Reference Only.

Part of ASSA ABLUY

DS160 Series High Performance Request-to-exit Detectors



- ▶ Door monitor with sounder alert
- ▶ Sequential Logic Input (SLI)
- ▶ Internal vertical pointability
- ▶ Wrap-around coverage pattern with precise pattern control
- ▶ Up to 64 second adjustable latch time
- ▶ Selectable relay trigger mode
- ▶ Selectable fail safe/fail secure modes
- ▶ Adjustable sounder volume
- ▶ Activation LED

The DS160 Series consists of the DS160 Detector (light gray) and the DS161 Detector (black) specifically designed for Request-to-exit (REX) applications. With features such as timers, door monitor with sounder alert, and pointable coverage, the DS160 and DS161 have the flexibility to meet the most stringent REX requirements. The exclusive Sequential Logic Input (SLI) provides added security that is not offered in any other REX device.

System overview

Functions

Sequential Logic Input (SLI)

The SLI terminal allows connection of a second device to require sequential detection. This eliminates the possibility that an object that is slid through the door or underneath the door will activate the detector. This input can also be used to lock the sensor if motion is present outside the premises.

Door Monitor

The sensor can monitor a door contact to allow special control of the internal relay. For example, if the door is opened within the relay time period, the sensor can be programmed to halt the timer. If the door is not opened within a specific time period, the relay can be programmed to deactivate.

Sounder Alert

An integrated sounder can be programmed to activate if the door is left open too long. The sounder volume is fully adjustable to 85 dB.

Keycard Input

The keycard input allows the sensor relay to be controlled from an external source, such as an access control system or card reader.

Regulatory information

Europe Complies with EN50131-1 Grade 2

Region	Regulatory compliance/quality marks	
Europe	CE	
USA	UL	ALVY: Access Control Systems Units (UL294) [DS160, DS161]
Australia	RCM	[DS160]

Installation/configuration notes

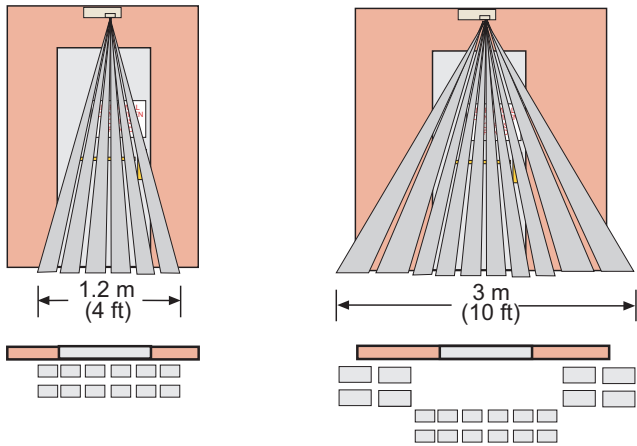

Front View
 Mounted on wall above door and mounted on ceiling .75 m (2.5 ft) in front of the door.

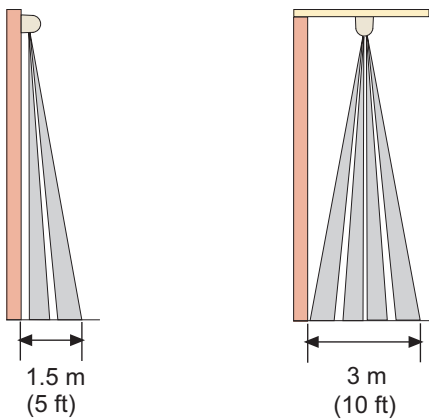

Side View
 The higher that you mount the unit, the larger the coverage area. Do not mount the DS160/DS161 more than 4.6 m (15 ft) above the floor.
 Side view of coverage pattern with the unit mounted at 4.6 m (15 ft) above the floor with the lens pointed straight down.

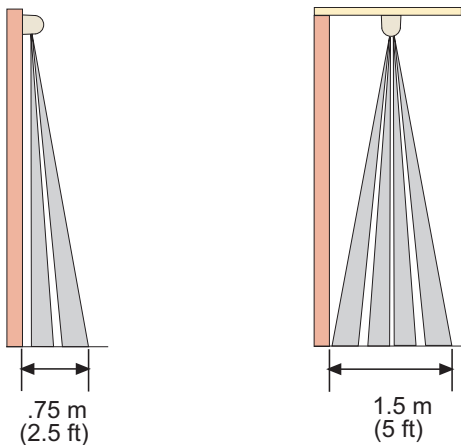

Side View
 The higher that you mount the unit, the larger the coverage area. Do not mount the DS160/DS161 more than 4.6 m (15 ft) above the floor.

Side view of coverage pattern with the unit mounted at 4.6 m (15 ft) above the floor with the lens pointed straight down.

Coverage Information
 The coverage (detection area) varies depending on the mounting height above the floor, angle of the lens, and whether the unit is mounted on a wall above the door or on the ceiling. The coverage is 2.4 m x 3 m (8 ft x 10 ft) The coverage patterns for the detector at a height of 2.3 m (7.5 ft) are shown. The coverage pattern increases or decreases with height and detector alignment.

Notice
 When you mount the unit on the wall and the lens points straight down, some detection zones point toward the wall and do not detect movement.

The diagrams depict views of the coverage pattern with the detector mounted at 2.3 m (7.5 ft) above the floor with the lens pointed straight down. Zones that are pointed toward the wall are not shown.

Parts included

Technical specifications

Environmental

Operating Temperature:	-29°C to +49°C (-20°F to +120°F) For UL Certificated installations, 0°C to +49°C (+32°F to +120°F)
Radio Frequency Interference (RFI) Immunity:	No alarm or setup on critical frequencies in the range from 26 MHz to 1000 MHz at 50 V/m

Complies with Environmental Class II (EN50130-5)

Mechanical

Dimensions:	4.5 cm x 17.1cm x 4.4 cm (1.80 in. x 6.75 in. x 1.75 in.)
Material:	High impact ABS plastic enclosure

Modes

Power Loss Default:	Programmable fail-safe or fail-secure modes.
Timer:	Programmable reset accumulative or non-reset counting mode.

Electrical

Current Draw:	8 mA nominal standby current, 39 mA at 12 VDC in alarm
---------------	--

Voltage:	12 VAC or VDC to 30 VAC or VDC
Alarm Output:	Two Form C relay contacts each rated 1 A at 30 VAC or VDC for resistive loads
Indicators:	1 activation LED
Relay Latch Time:	Adjustable from 0.5 sec to 64 sec.

Ordering information

DS160 Request-to-exit sensor, sounder

For use in request-to-exit (REX) applications. Provides PIR 2.4 m x 3 m (8 ft x 10 ft) coverage, timers, door monitor with sounder alert, and pointable coverage.
 Order number **DS160 | 4.998.800.238 F.01U.364.868 F.01U.405.131**

DS161 Request-to-exit sensor, black, sounder

Black enclosure. For use in Request-to-Exit (REX) applications. Provides PIR, 2.4 m x 3 m (8 ft x 10 ft) coverage, timers, door monitor with sounder alert, and pointable coverage.
 Order number **DS161 | 4.998.800.239 F.01U.364.869 F.01U.405.132**

Accessories

TP160 Trim plate for DS150 and DS160

A light gray trim plate used when mounting the detector over a standard single-gang box.
 Order number **TP160 | 4.998.800.318**

TP161 Trim plate for DS151 and DS161, black

A black trim plate used when mounting the sensor over a standard single-gang box.
 Order number **TP161 | 4.998.130.552**

Represented by:

Europe, Middle East, Africa:
 Bosch Security Systems B.V.
 P.O. Box 80002
 5600 JB Eindhoven, The Netherlands
www.boschsecurity.com/xc/en/contact/

Germany:
 Bosch Sicherheitssysteme GmbH
 Robert-Bosch-Platz 1
 D-70839 Gerlingen
www.boschsecurity.com

North America:
 Bosch Security Systems, LLC
 130 Perinton Parkway
 Fairport, New York, 14450, USA
www.boschsecurity.com

Asia-Pacific:
 Robert Bosch (SEA) Pte Ltd, Security Systems
 11 Bishan Street 21
 Singapore 573943
www.boschsecurity.com/xc/en/contact/

Miami Dade County Department of Regulatory and Economic Resources - Job Copy

3225016727 - 7/29/2025 3:14:23 PM
 Data subject to change without notice | 202406111545 | V20 | June 11, 2024
 COMBINED CUT SHEET_V2.pdf

Examiner **Date Time Stamp** **Trade Stamp Name**
 CARTER, THOMAS J. 7/29/2025 3:06:16 PM FIRE Reference Only.

MIAMI-DADE COUNTY

DEPARTMENT OF REGULATORY AND ECONOMIC RESOURCES

<http://www.miamidade.gov/building/home.asp>

7/14/2025 11:26:07 AM

Contact Name: Guillermo Gonzalez
Contact Email: OUTI.BATTENFIELD@JCI.COM
Tracking Number: 3225016727
Reviews to rework: FIRE
Comments:

Miami-Dade Department of Regulatory and Economic Resources
CONTACT INFORMATION FOR PERMIT APPLICATION

FIRST NAME (print clearly) Outi	LAST NAME (print clearly) Battenfield
MOBILE PHONE 954 624 9898	OFFICE/HOME PHONE 954 624 9824
EMAIL (required so you can be notified on the status of your plans) outi.battenfield@jci.com	
COMMENTS (if you are submitting a municipal plan, please provide the municipal process number(s) and ensure the municipal application is in the city set of plans.)	

PLANS (check all that apply)

Please indicate if plans qualify for the following expedited plan reviews:

- | | | |
|--|--|--|
| <input type="checkbox"/> GOVT PROJECT/DEPT | <input type="checkbox"/> GREEN BLDG* (new construction only) | <input type="checkbox"/> FACE PROJECT* |
| <input type="checkbox"/> AFFORDABLE/WORKFORCE HOUSING* | <input type="checkbox"/> ECONOMIC SIGNIFICANCE* | <input type="checkbox"/> CONCERGE |
- (*Pursuant to Ordinance 99-140; Ordinance 08-175 and Ordinance 08-87. Project may have additional requirements.)

REQUESTED PLAN REVIEWS (check all that apply for rework only)

- | | | | | | |
|--------------------------------------|--|---|---|--|---|
| <input type="checkbox"/> ALL | <input type="checkbox"/> BLDG/HCAP | <input type="checkbox"/> ELEC | <input type="checkbox"/> ENRG | <input checked="" type="checkbox"/> FIRE | <input type="checkbox"/> ROOF |
| <input type="checkbox"/> LANDSCAPING | <input type="checkbox"/> MECH | <input type="checkbox"/> PLUM | <input type="checkbox"/> PWKS | <input type="checkbox"/> PWCC | <input type="checkbox"/> SIGN |
| <input type="checkbox"/> STRU | <input type="checkbox"/> ZNPR | <input type="checkbox"/> WABD | <input type="checkbox"/> PWIF | <input type="checkbox"/> LPGX | <input type="checkbox"/> SHOP DRAWING |
| <input type="checkbox"/> DERM CORE | <input type="checkbox"/> DERM AIR | <input type="checkbox"/> DERM AIRPORT | <input type="checkbox"/> DERM ASBESTOS | <input type="checkbox"/> DERM COASTAL | <input type="checkbox"/> DERM FLOOD |
| <input type="checkbox"/> DERM GREASE | <input type="checkbox"/> DERM INDUSTRIAL | <input type="checkbox"/> DERM PAVING & DRAINAGE | <input type="checkbox"/> DERM POLLUTION | <input type="checkbox"/> DERM PRE-TREATMENT | <input type="checkbox"/> DERM SOLID WASTE |
| <input type="checkbox"/> DERM TANKS | <input type="checkbox"/> DERM TREES | <input type="checkbox"/> DERM WATER TREATMENT | <input type="checkbox"/> DERM WETLANDS | <input type="checkbox"/> PERMIT BY AFFIDAVIT CHECK | <input type="checkbox"/> SHORT TERM EVENT AFFIDAVIT CHECK |

OPTIONAL PLAN REVIEWS (check all that apply)

- | | | | | |
|-------------------------------|-------------------------------|-------------------------------|-------------------------------|-------------------------------|
| <input type="checkbox"/> BLDG | <input type="checkbox"/> ELEC | <input type="checkbox"/> MECH | <input type="checkbox"/> PLUM | <input type="checkbox"/> STRU |
|-------------------------------|-------------------------------|-------------------------------|-------------------------------|-------------------------------|

OPR DERM INITIAL REVIEWS (check all that apply)

- | | |
|------------------------------------|--|
| <input type="checkbox"/> DERM CORE | <input type="checkbox"/> DERM SPECIALTY (You will be notified after core review is complete for additional fees) |
|------------------------------------|--|

OPR DERM REWORK (OPR for specialty only available at PIC)

- | | | | | | |
|--------------------------------|-------------------------------------|-----------------------------------|--|-------------------------------|--|
| <input type="checkbox"/> TREE | <input type="checkbox"/> GREASE | <input type="checkbox"/> ASBESTOS | <input type="checkbox"/> COASTAL | <input type="checkbox"/> AIR | <input type="checkbox"/> PAVING & DRAINAGE |
| <input type="checkbox"/> TANKS | <input type="checkbox"/> INDUSTRIAL | <input type="checkbox"/> WETLAND | <input type="checkbox"/> PRE-TREATMENT | <input type="checkbox"/> CORE | <input type="checkbox"/> FLOOD |

FOR OFFICE USE ONLY

To be completed by Permit and Occupancy Representative or Plans Processing Specialist

APPLICATION DATE	CLERK NAME	ARRIVAL TIME
PROCESS NUMBER	PROCESS NUMBER	PROCESS NUMBER

Select Medical
14472521-02



6601 Main St • Miami Lakes, Florida, 33014
Office: (305) 827-4015 • Fax: (305) 558-9884
Website: www.miamilakes-fl.gov

BUILDING PERMIT APPLICATION

Job Address: 14001 NW 82ave

Unit #:

Folio #: 32-2022-040-0028 Owner-Builder:

Master Permit #: BLL2024-0975 Sub Permit #: _____ Revision #: _____

OWNER INFORMATION	NAME: <u>TGC LLC LLC</u>	LEGAL USE/ WORK	Current Use of Property: <u>Commercial</u>
	Address: <u>6843 Main St</u>		Job Description: <u>ACCESS CONTROL</u>
	City, State, Zip: <u>Miami Lakes FL 33015</u>		JOB COST \$ <u>38109.00</u> AREA/LENGTH: _____ SF/LF
	Phone #: _____ Cell #: _____		Residential <input type="checkbox"/> Multi-Family <input type="checkbox"/> Commercial <input type="checkbox"/> Industrial <input checked="" type="checkbox"/>
Email Address: _____		Code in Effect: _____	
CONTRACTOR INFORMATION	Company Name: JOHNSON CONTROL SECURITY SOLUTIONS	ARCHITECT/ ENGINEER	Firm Name: _____
	Qualifier Name: FITZPATRICK, JASON ALEXANDER		A/E of record: _____
	License # <u>EF20000452</u>		License # _____
	Address <u>15901 SW 29th Street #801</u>		Address _____
	City, State, Zip <u>Miramar, FL, 33027</u>		City, State, Zip _____
	Phone #: <u>954-624-9824</u> Cell #: _____		Phone #: _____ Cell #: _____
Email Address: <u>Outi.battenfield@jci.com</u>		Email Address: _____	
Permit Type -- Check only One		Change to Permit -- Check only One	
<input type="checkbox"/> Building <input checked="" type="checkbox"/> Electrical <input type="checkbox"/> Mechanical <input type="checkbox"/> Plumbing/Gas <input type="checkbox"/> Paving/Drainage <input type="checkbox"/> Sign <input type="checkbox"/> Roofing <input type="checkbox"/> P/W		<input type="checkbox"/> Extension <input type="checkbox"/> Renewal <input type="checkbox"/> Revision <input type="checkbox"/> Change Contractor <input type="checkbox"/> Shop Drawing <input type="checkbox"/> Cancellation	

Application is hereby made to obtain a permit to do work and installation as indicated. I certify that no work or installation has commenced prior to the issuance of a permit and that all work will be performed to meet the standards, of all laws regulating construction in this jurisdiction. I understand that a separate permit must be secured for ELECTRICAL WORK, MECHANICAL, PLUMBING, SIGNS, WELLS, POOLS, RE-ROOFING, SHUTTERS, WINDOWS, FURNACES, BOILERS, HEATERS, TANKS, and AIR CONDITIONERS, etc. I understand that in signing this application I am responsible for the supervision and completion of the construction including scheduling of inspections and obtaining final inspections in accordance with the plans and specification WARNING TO OWNER: YOUR FAILURE TO RECORD A NOTICE OF COMMENCEMENT MAY RESULT IN YOU PAYING TWICE FOR IMPROVEMENTS TO YOUR PROPERTY. IF YOU INTEND TO OBTAIN FINANCING, CONSULT WITH YOUR ATTORNEY OR LENDER BEFORE RECORDING YOUR NOTICE OF COMMENCEMENT. OWNER/CONTRACTOR AFFIDAVIT: I Certify that all the foregoing information is accurate and that all work will be done in compliance with all applicable laws regulating construction and zoning.

X
Signature of Owner or Owner's Agent _____ Date _____

X [Signature]
Signature of Qualifier _____ Date 11-18-24

Print Name of Owner or Owner's Agent _____

Print Name of Qualifier _____

STATE OF _____ COUNTY OF _____
Sworn to and subscribed before me this _____ 20____
by _____ (SEAL)
Personally known or I.D. _____

STATE OF FLORIDA COUNTY OF Broward
Sworn to and subscribed before me this 11-18 2024
by Jason Fitzpatrick (SEAL)
Personally known or I.D. _____

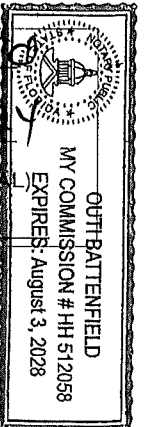

NOTICE: In addition to the requirements of this permit, there may be additional deed restrictions enforced by the homeowner's associations that may be applicable to this property that may be found in the public records of this county, and there may be additional permits required from other governmental entities such as water management districts, state agencies, or federal agencies.

NOTE: This application will be void if there are no reviews after six(6) months.

MIAMI-DADE COUNTY

DEPARTMENT OF REGULATORY AND ECONOMIC RESOURCES

<http://www.miamidade.gov/building/home.asp>

7/29/2025 3:14:23 PM

Tracking #	Process #	Permit #
3225016727	M2025016727	2025061604

THIS COPY OF PLANS MUST BE AVAILABLE ON BUILDING SITE OR AN INSPECTION WILL NOT BE MADE.				
Process #	Review	Disposition	Reviewer	Date
M2025016727	FIRE	A	CARTER, THOMAS J.	7/29/2025
M2025016727	UPFRONT FEES	A	WEB APPLICATION ID	5/30/2025

Disclaimer.

Subject to compliance with all Federal, State, and County Laws, rules and regulations. Miami-Dade County assumes no responsibility for accuracy of or results of these plans.

NOTICE: In addition to the requirements of this permit, there may be additional restrictions applicable to the property that may be found in the public records of this county, and there may be additional permits required from other governmental entities such as water management districts, state agencies or federal agencies.

Stamp Name	Trade	Disposition	Stamp Description
APPROVED-SCOPE ONLY	FIRE	A	APPROVAL FOR SCOPE OF WORK ONLY EXISTING PORTIONS OF BUILDINGS SHALL COMPLY WITH THE PROVISIONS OF EXISTING OCCUPANCIES AS SET FORTH IN THE FL FIRE PREVENTION CODE
Reference Only.	FIRE	R	Reference only.
Void	FIRE	V	Void



Miami-Dade Fire Rescue Life Safety Pre-Submittal Checklist



Process #	Permit #	YES	NO	N/A	Date: 5/22/2025
	Fire Department Application #				LOCATION/COMMENTS
	Project Name: <u>Selcet Medical - STRATEGIS</u>	/			
	Address: <u>14001 NW 82ND AVENUE</u>	/			
	<u>MIAMI LAKES, FL 33016</u>	/			
1	Do your plans include all applicable information as required by NFPA 1 (2003) (A.1.14.1) And are the plans signed and sealed by a professional architect or engineer? (design professional's contact info must be legible)	/			
2	Are there a minimum two sets of plans being submitted (job copy and office copy)?	/			
3	If the submittal is for a revision, are the original job copy (or certified microfilm) and two copies of the revision being submitted?			/	
4	Have plans been provided with the approved "Impact Fee Stamp" (for municipalities)			/	
5	If plan is for new development/construction, has a "siteplan" including fire hydrant locations and fire flow, fire lanes, emergency vehicle turning radius, etc. been approved for this new development? Attach copies of approved siteplan.?			/	
6	Has the "water extension number" been provided for all new fire hydrants?			/	
7	Is there a "location plan" provided? (i.e. the area in which the scope of the work is located within a larger building)			/	
8	If the plan is for a new building, is the construction type identified on the plans and in accordance with NFPA 101 (8.2.1)			/	
9	Is the scope of the work to be performed clearly stated on the plans?	/			
10	Is any portion of the work being done to remedy a violation relating to construction that was originally done without a permit?			/	
11	Is the building provided with a fire sprinkler system and/or a fire alarm system and is that indicated on the plan? (separate plans for installation or modifications required)			/	
12	If submittal is for a new building with a fire sprinkler system, do the fire protection system engineering documents include all of the requirements found in the Florida Administrative Code 61G15-32.004 (2) (a) through (j)			/	
13	Are the existing conditions and existing construction clearly identified and distinguishable from the new construction or scope of the new work?	/			
14	Has the occupancy classification for the area in which the scope of the work is being conducted been identified on the plan in accordance with NFPA 101 (6.1)?	/			
15	Is the occupancy in which the scope of the work is being conducted separated from neighboring occupancies with the fire resistance rating prescribed by NFPA 101 (6.1.14.4.1) (IDENTIFY THE NEIGHBORING OCCUPANCIES ON THE PLAN)?			/	
16	Is the classification of hazard identified in accordance with NFPA 101 (6.2)?			/	
17	Where required, has the means of egress been separated from the rest of the building with fire resistive construction in accordance with NFPA 101 (7.1.3)			/	
18	Has the interior wall, ceiling, and floor finish been identified on the plans and meet the requirements of NFPA 101 (7.1.4)	/			
19	Is headroom within the means of egress a minimum 7'6" with projections not less than 6'8" in accordance with NFPA 101 (7.1.5)?			/	
20	Do changes in the means of egress not exceed 1/2" in accordance with NFPA 101 (7.1.6.2)?	/			
21	Do all doors in a means of egress meet the requirements of NFPA 101 (7.2.1)	/			
22	Do all doors in a means of egress meet the minimum door width requirements of NFPA 101 (7.2.1.2.4)	/			
23	Are all doors in a means of egress scheduled to be equipped with locking and latching hardware that does not require a key, tool, or special knowledge or effort from the egress side. ALL DOOR HARDWARE MUST COMPLY WITH NFPA 101 (7.2.1.5)	/			
24	Do all doors equipped with special locking arrangements such as delayed-egress locks and access controlled egress doors comply with the requirements of NFPA 101 (7.2.1.6)	/			
25	Where required, are egress doors equipped with panic hardware or fire exit hardware in accordance with NFPA 101 (7.2.1.7)? Only approved panic hardware shall be used on doors that are not fire doors. Only approved FIRE EXIT HARDWARE shall be used on FIRE DOORS.	/			
26	Are doors that are required to be kept closed, such as doors in fire barriers and smoke barriers, self closing or automatic closing in accordance with NFPA 101 (7.2.1.8)			/	

Designed by: ALBERTO QUINTANA Phone #: 954 830-7542



Miami-Dade Fire Rescue Life Safety Pre-Submittal Checklist



27	Are all stairs designed with proper tread, riser, handrail, guardrail, and all required criteria in accordance with NFPA 101 (7.2.2)	YES	NO	N/A	
28	Are all ramps designed with the proper slope, landings, handrails, guardrails and all required criteria in accordance with NFPA 101 (7.2.5)			/	
29	Has the number of occupants for the occupancy class been calculated and identified in accordance with NFPA 101 (7.3.1.2 Table)?			/	
30	Has the minimum number of exits been provided in accordance with NFPA 101 (7.4) and the occupancy chapter?			/	
31	Are required exits remotely located and arranged in accordance with NFPA 101 (7.5)?	/			
32	Is access to required exits not through kitchens, storerooms, restrooms, closets and other rooms or spaces subject to locking and all other possible impediments to egress in accordance with NFPA 101 (7.5.2)?			/	
33	Is the means of egress shown completely to a public way and is the means of egress "accessible" in accordance with NFPA 101 (7.5.4)?	/			
34	Has the measurement of travel distance for "common path", "dead end", and "travel distance to exits" been provided in accordance with NFPA 101 (7-6) and the specific occupancy requirements?			/	
35	Do exits discharge at a public way in accordance with NFPA 101 (7.7) OR if exits discharge through areas on the level of exit discharge are those exits in compliance with NFPA 101 (7.7.2)?			/	
36	Is illumination of the means of egress in accordance with NFPA 101 (7.8)?			/	
37	Is emergency lighting for the means of egress in accordance with NFPA 101 (7.9) and the specific occupancy requirements?			/	
38	Will the performance and installation of the emergency lighting system comply with the requirements of NFPA 101 (7.9.2)?			/	
39	Are exits and the directions to exits marked with signs that will meet the requirements of NFPA 101 (7.10) that clearly identify exits and access thereto.?			/	
40	Have specialty exit signs such as "exit stair door tactile signage" and "floor proximity exit signs" that may be required by 7.10.1.3, 7.10.1.6, 7.10.1.8 AND/OR signs required for the particular occupancy type or chapter been provided?			/	
41	Have occupancies and/or areas deemed to contain "High Hazard Contents" met the special requirements of NFPA (7.11) for travel distance, egress capacity, door swing, etc.			/	
42	Are all areas required to be separated from the remainder of the building with fire resistive construction properly identified with the hourly rating, and, has the construction method to achieve that rating also been identified in accordance with NFPA 101 (8.2 and 8.3)?(i.e., stair enclosures, corridors, exit passageways, storage areas, etc.?			/	
43	Are all penetrations in required smoke partitions and smoke barriers such as pipes conduits, joints, air-transfer openings, etc. protected in accordance with NFPA 101 (8.4) and (8.5)			/	
44	Are all vertical openings between floors protected as required by NFPA 101 (8.6)			/	
45	Are atriums designed in accordance with NFPA 101 (8.6.7)			/	
46	Are mezzanines designed in accordance with NFPA 101 (8.6.9) and the specific occupancy requirements.			/	
47	Do mezzanines not exceed one-third of the open area of the room in which they are located in accordance with NFPA 101 (8.6.9.2.1)			/	
48	Are mezzanines open to and unobstructed from the room in which the mezzanines are located in accordance with NFPA 101 (8.6.9.3)			/	
49	Are areas having a degree of hazard greater than that normal to the general occupancy protected in accordance with NFPA 101 (8.7).			/	
50	Are all cooking appliances provided with appropriate ventilation and fire suppression equipment in accordance with NFPA 101 (9.2.3)			/	
51	Are all interior wall, ceiling, and floor finishes detailed on the plan and in compliance with NFPA 101 (10.2)			/	
52	Are all contents and furnishings such as curtains, draperies, decorations, upholstered furniture and mattresses, when required by the specific occupancy, fire retardant in accordance with NFPA 101 Chapter 10			/	
53	Do all special structures such as towers, water surrounded structures, piers, vehicles and vessels, and underground structures meet the specific occupancy requirements and the special requirements of NFPA 101 Chapter 11?			/	
54	Have all hi-rise structures been provided with all the specific life-safety features required by NFPA 101 (11.8)			/	

Designed by: _____ Phone #: _____

14972521-02
Select Medical

NOTE: ALL SHEETS MUST BE REVIEWED

MIAMI-DADE COUNTY DEPARTMENT OF REGULATORY AND ECONOMIC RESOURCES

Herbert S. Saffir Permitting and Inspection Center

11805 SW 26th Street (Coral Way) • Miami, Florida 33175-2474 • (786) 315-2000

**APPLICATION FOR MUNICIPAL PERMIT APPLICANTS
THAT REQUIRE PLAN REVIEW FROM MIAMI-DADE FIRE RESCUE
AND/OR ENVIRONMENTAL SERVICES**

M2025016727

SEL2025-1459

3225016727

PROVIDE MUNICIPAL PROCESS NUMBER HERE			
LOCATION OF IMPROVEMENTS	Job Address <u>14001 NW 82 ave</u>	CONTRACTOR INFORMATION	Contractor No. <u>EF20000452</u>
	Folio <u>32-2022-040-0020</u>		Last four (4) digits of Qualifier No. <u>8126</u>
	Lot _____ Block _____		Contractor Name <u>Johnson Controls Security</u>
	Subdivision _____ PBpg _____		Qualifier Name <u>Jason Fitzpatrick</u>
	Metes and bounds _____		Address <u>15901 SW 29 St ste 801</u>
			City <u>Miramar</u> State <u>FL</u> Zip <u>33027</u>
TYPE OF IMPROVEMENTS	<input type="checkbox"/> New Construction on Vacant Land	<input type="checkbox"/> Demolish	Current use of property _____ <u>COMMERCIAL</u>
	<input checked="" type="checkbox"/> Alteration Interior	<input type="checkbox"/> Shell Only	
	<input type="checkbox"/> Alteration Exterior	<input type="checkbox"/> Addition Attached	Sq. Ft. _____ Units _____ Floors _____
	<input type="checkbox"/> Relocation of Structure	<input type="checkbox"/> Addition Detached	Value of Work <u>38109.00</u>
	<input type="checkbox"/> Enclosure	<input type="checkbox"/> Re-Roof	
	<input type="checkbox"/> Repair	<input type="checkbox"/> Foundation Only	
	<input type="checkbox"/> Repair Due to Fire	<input type="checkbox"/> Tent	
PERMIT TYPE	<input type="checkbox"/> MBLD* Category _____	REVIEW STATUS	PROPERTY OWNER'S INFO
	<input checked="" type="checkbox"/> MELE <u>04</u>		
	<input type="checkbox"/> MPLU _____	<input type="checkbox"/> Re-Issue	Owner <u>TGC LLC</u>
	<input type="checkbox"/> MLPG _____	<input type="checkbox"/> Re-Stamp	Address <u>6843 main st</u>
	<input type="checkbox"/> MMEC _____	<input type="checkbox"/> Revision	City <u>MiDKS</u> State <u>FL</u> Zip <u>33015</u>
	<input type="checkbox"/> FIRE _____	<input type="checkbox"/> Not Applicable for Fire	Phone _____
			Last four (4) digits of Owner's Social Security No. _____
PERMIT CONTACT	Name <u>Outi Battenfield</u>	ARCHITECT / ENGINEER	Owner _____
	Address <u>15901 SW 29 St ste 801</u>		Address _____
	City <u>Miramar</u> State <u>FL</u> Zip <u>33027</u>		City _____ State _____ Zip _____
	Phone <u>954-624-9824</u>		Phone _____
FIRE SPECIAL REQUEST PLAN REVIEW (SRI)	<i>I am requesting a Special Request Plan Review (SRI) to be scheduled as soon as possible. There is a minimum charge of one-hour. Please contact the Fire Department for current rate.</i>		
	1st Request: _____	Date: _____	
	2nd Request: _____	Date: _____	
	3rd Request: _____	Date: _____	
<p>If the applicant is a known named violator with: unpaid civil penalties; unpaid administrative costs of hearing; unpaid County investigative, enforcement, testing, or monitoring costs; or unpaid liens, any or all of which are owed to Miami-Dade County pursuant to the provisions of the Code of Miami-Dade County, Florida, a hold on the review may be placed on this application.</p>			

PRO4200

Two Reader Module (PRO42R2/PRO42R2B)

Installation Guide

Copyright© 2022 Honeywell. All rights reserved.

All product and brand names are the service marks, trademarks, registered trademarks, or registered service marks of their respective owners. Printed in the United States of America. Honeywell reserves the right to change any information in this document at any time without prior notice.

WIN-PAK® is a trademark of Honeywell International, Inc.

Ordering Information

Please contact your local Honeywell representative or visit us on the web at www.honeywellaccess.com for information about ordering.

Feedback

Honeywell appreciates your comments about this manual. Please visit us on the web at www.honeywellaccess.com to post your comments.

Technical Support Self-Service | Customer Portal

<https://myhoneywellbuildingsuniversity.com/training/support/>

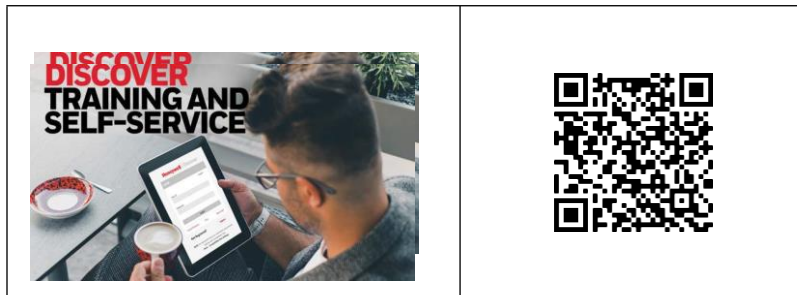

YouTube | Honeywell Help and Support

https://www.youtube.com/channel/UCBEL6ouNV_LN5lEpYRujMTg/featured

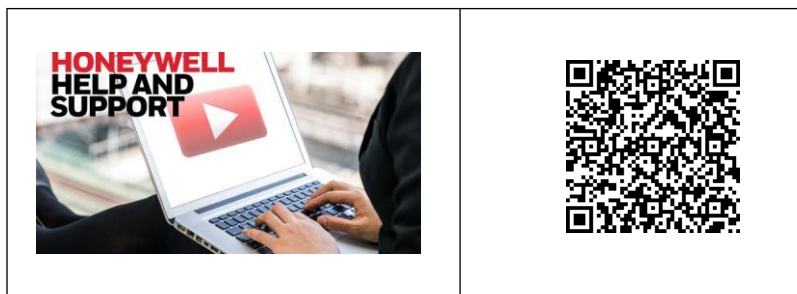

CONTENTS

Notices

Notices	3
---------------	---

Notices..... 5

Warnings and Cautions	5
Compliance	7
Conformité	8
Avertissements et mises en garde.....	8
Disclaimer	11
Compliance	11
CE and WEEE Marking	12
Unpacking Procedure	12
Shipping Instructions.....	13
Limited Warranty.....	13
Confidentiality.....	14

Installing the PRO4200 Two Reader Module 15

Description	15
Specification.....	16
Set Up	17
LED Operation.....	19
Power	20
Communications	21
Wiring	21
Reader Wiring	28
Input Wiring.....	29
Control Output Wiring	29
Mounting Options	29
Installing the Module	29

2-Reader Input Module Programming Guide..... 32

(This page is left blank intentionally for double-sided printing.)

Notices

Warnings and Cautions

Wiring methods shall be in accordance with the National Electrical Code (ANSI/NFPA70), Canadian Electrical Code, Part I (CSA C22.1) Safety Standard for Electrical Installations, local codes, and the authorities having jurisdiction.



Warning

Before connecting the device to the power supply, verify that the output voltage is within specifications of the power supply.

Not Evaluated by UL for fire, life safety, or burglary applications.

Do not apply power to the system until **after** the installation has been completed. Personal injury or death could occur, and the equipment could be damaged beyond repair, if this precaution is not observed!



Warning: Fire Safety and Liability Notice

Never connect card readers to any critical entry, exit door, barrier, elevator, or gate without providing **an alternative exit** in accordance with all fire and life safety codes pertinent to the installation. These fire and safety codes vary from city to city and you must get approval from local fire officials whenever using an electronic product to control a door or other barrier. Use of egress buttons, for example, may be illegal in some cities. In most applications, single action exit without prior knowledge of what to do is a life safety requirement. Always make certain that any required approvals are obtained in writing. **DO NOT ACCEPT VERBAL APPROVALS, BECAUSE THEY ARE NOT VALID.**

Honeywell never recommends using the PRO4200 or related products for use as a primary warning or monitoring system. Primary warning or monitoring systems should always meet local fire and safety code requirements. The installer must also test the system on a regular basis by instructing the end user in appropriate daily testing procedures. Failure to test a system regularly could make the installer liable for damages to the end user if a problem occurs.



Note: See the Remote Enclosure Installation manuals PRO22ENC1, PRO22ENC2, PRO22ENC3 or PRO22ENC5 for installation instructions.



Warning:

EARTH ground all enclosures for proper installation.



Warning:

The S-4 Suppressor Kit must be installed with every electrical switching device connected through a relay contact, without regard to polarity. One S-4 is installed

across the relay at the panel and the other is installed within 18 inches of the electrical switching device.

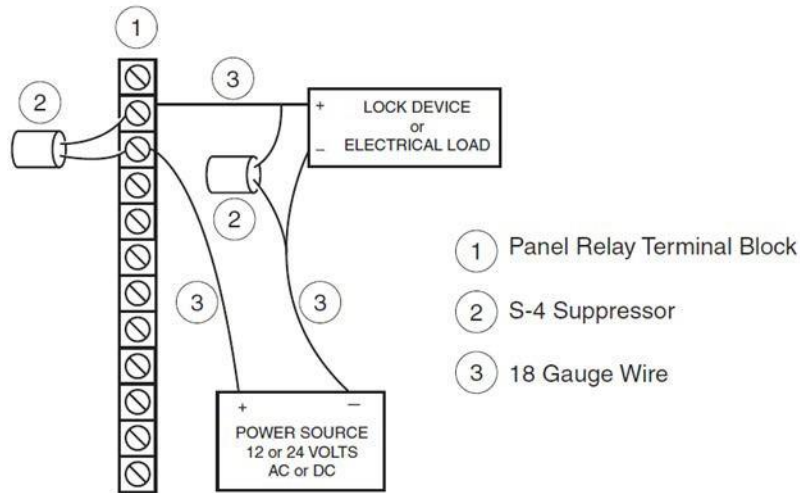

Caution:

IF ANY DAMAGE TO THE SHIPMENT IS NOTICED, A CLAIM MUST BE FILED WITH THE COMMERCIAL CARRIER RESPONSIBLE.



Caution: Electrostatic discharge can damage CMOS integrated circuits and modules. To prevent damage, always follow these procedures:

- Use static shield packaging and containers to transport all electronic components, including completed reader assemblies.
- Handle all ESD sensitive components at an approved static-controlled workstation. These workstations consist of a desk mat, a floor mat, and an ESD wrist strap. Workstations are available from various vendors.



Note: This equipment has been tested and found to comply with the limits for a Class A digital device, pursuant to part 15 of the FCC Rules. These limits are designed to provide reasonable protection against harmful interference when the equipment is operated in a commercial environment. This equipment generates, uses, and can radiate radio frequency energy and, if not installed and used in accordance with the instruction manual, may cause harmful interference to radio communications. Operation of this equipment in a residential area is likely to cause harmful interference, in which case the user will be required to correct the interference at his own expense.



Note: This document and the data in it shall not be duplicated, used, or disclosed to others for procurement or manufacture, except as authorized by and with the written permission of, Honeywell, Inc. The information contained in this document or in the product itself is considered the exclusive property and trade secrets of Honeywell, Inc. Copyright laws of the United States protect all information in this document or in the software product itself.



Note: Any use of this product is subject to the terms and acceptance of the Honeywell, Inc. Software Agreement. Please request a copy from Honeywell, Inc., and review the agreement carefully.

Compliance

A separately provided Power Supply shall be Listed to ULC 60830-11-1 Grade 1 minimum, or ULC-S319 Listed Grade 1 minimum or ULC-S318 Listed.

The fail secure locking mechanism shall only be installed where is allowed by the local authority having jurisdiction (AHJ), and it shall not impair the operation of panic hardware and emergency egress.



Note: Door strike time is configurable at each reader point.



Note: RS-485 wiring was evaluated in the enclosure for the ULC 60839-11-1 certification, wiring length details of 4000 ft does not apply to the Reader board. Wiring must remain inside enclosure for ULC 60839-11-1 installations.

The following table summarizes the standards each model was evaluated to.

Standards	SKU			
	PW7K1R2	PW7K1R2B	PRO42R2	PRO42R2B
UL294	X	X	X	X
UL293	X	X	X	X
ULC S319	X	N/A	X	N/A
ULC 60839-11-1	N/A	X	N/A	X

The Model PW7K1R2B/PRO42R2B is to be installed inside the controlled area and is to be installed in a separate ULC Listed locking metal enclosure with IP4X and IK04 Ratings.

The Model PW7K1RB/PRO42R2B Reader Board intended to be used in indoor dry conditions.

System employs Token Use only for Recognition Requirements.

The Model PW7K1R2B/PRO42R2B employs all the mandatory Grade Level 1 functions under ULC 60839-11-1, except for the functions that are not employed.

The Model PW7K1R2B/PRO42R2B is a Reader Board and does not employ capability to store information.

The Model PW7K1R2B/PRO42R2B Reader Board does not employ configuration mode.

Duress Function not applicable as only verified Grade Level 1 under ULC 60839-11-1, functions with the separately Listed Honeywell OP40 Card Reader, which does not employ a keypad.

Conformité

Remarque: Le temps de gâche est configurable à chaque point de lecture.

Remarque: Le câblage RS-485 été évalué dans le boîtier pour la certification ULC 60839-11-1, la longueur de câblage de 4000 pieds ne s'applique pas à la carte de lecteur. Le câblage doit rester à l'intérieur de l'enceinte pour les installations ULC 60839-11-1.

Une alimentation électrique fournie séparément doit être répertoriée selon la norme ULC 60830-11-1 Grade 1 minimum, ou ULC-S319 Grade 1 minimum ou ULC-S318.

Le mécanisme de verrouillage à sécurité intégrée ne doit être installé que là où il est autorisé par l'autorité locale compétente (AHJ), et il ne doit pas entraver le fonctionnement de la quincaillerie anti-panique et l'évacuation d'urgence.

Norme	produit			
	PW7K1R2	PW7K1R2B	PRO42R2	PRO42R2B
UL294	X	X	X	X
UL293	X	X	X	X
ULC S319	X	N/A	X	N/A
ULC 60839-11-1	N/A	X	N/A	X

Le modèle PW7K1R2B/PRO42R2B doit être installé à l'intérieur de la zone contrôlée, dans un boîtier métallique distinct, homologué ULC et verrouillable, de classe IP4X et IK04.

La carte de lecteur modèle PW7K1RB/PRO42R2B est destinée à être utilisée dans des conditions intérieures sèches.

Le système utilise des jetons uniquement pour les exigences de reconnaissance.

Le modèle PW7K1RB/PRO42R2B utilise toutes les fonctions obligatoires de niveau 1 de la norme ULC 60839-11-1, à l'exception des fonctions qui ne sont pas utilisées.

Le modèle PW7K1R2B/PRO42R2B est une carte de lecture et ne permet pas de stocker des informations.

La carte de lecteur modèle PW7K1R2B/PRO42R2B n'utilise pas le mode de configuration.

La fonction de contrainte n'est pas applicable car elle n'a été vérifiée que pour les fonctions de niveau 1 avec le lecteur de carte OP40 d'Honeywell répertorié séparément, qui n'utilise pas de clavier.

Avertissements et mises en garde

Les méthodes de câblage doivent être conformes au Code national de l'électricité (ANSI/NFPA70), au Code canadien de l'électricité, Partie I (CSA C22.1), à la norme de sécurité pour les installations électriques, aux codes locaux et aux autorités compétentes.

Avertissement:

Avant de connecter l'appareil à l'alimentation électrique, vérifiez que la tension de sortie est conforme aux spécifications de l'alimentation électrique.



Non évalué par UL pour les applications d'incendie, de sécurité des personnes ou de cambriolage.

Ne mettez pas le système sous tension **tant** que l'installation n'est pas terminée. Le nonrespect de cette précaution peut entraîner des blessures ou la mort, ainsi que des dommages irréparables à l'équipement!

Avertissement:

- i. Avis de sécurité incendie et de responsabilité Ne connectez jamais de lecteurs de cartes à une porte d'entrée critique, une barrière, un ascenseur ou un portail critique sans prévoir de sortie alternative conformément à tous les codes de sécurité incendie et de sécurité des personnes applicables à l'installation. Ces codes d'incendie et de sécurité varient d'une ville à l'autre et vous devez obtenir l'approbation des responsables locaux de la lutte contre l'incendie lorsque vous utilisez un produit électronique pour contrôler une porte ou une autre barrière.



L'utilisation de boutons de sortie, par exemple, peut être illégale dans certaines villes. Dans la plupart des applications, une sortie à action unique sans connaissance préalable de ce qu'il faut faire est une exigence de sécurité des personnes.

Assurez-vous toujours que toutes les approbations requises sont obtenues par écrit. **NE PAS ACCEPTER D'APPROBATIONS VERBALES, CAR ELLES NE SONT PAS VALABLES.** Honeywell ne recommande jamais l'utilisation du PW-7000 ou de produits connexes comme système primaire d'alerte ou de surveillance. Les systèmes primaires d'avertissement ou de surveillance doivent toujours être conformes aux exigences des codes locaux de sécurité et d'incendie. L'installateur doit également tester le système de façon régulière en indiquant à l'utilisateur final les procédures de test quotidiennes appropriées. Le fait de ne pas tester régulièrement un système peut rendre l'installateur responsable des dommages causés à l'utilisateur final en cas de problème.

Remarque: Pour les instructions d'installation, voir les manuels d'installation des boîtiers distants pour PW5K2ENC1/PW5K2ENC2 ou PW5K1ENC3.

Avertissement:



METTRE À LA TERRE tous les boîtiers pour une installation correcte."

Avertissement



Le kit de suppression S-4 doit être installé avec chaque dispositif de commutation électrique connecté par un contact de relais, sans tenir compte de la polarité. Un S-4

Notices

Avertissements et mises en garde

est installé sur le relais au panneau et l'autre est installé à moins de 18 pouces du dispositif de commutation électrique.

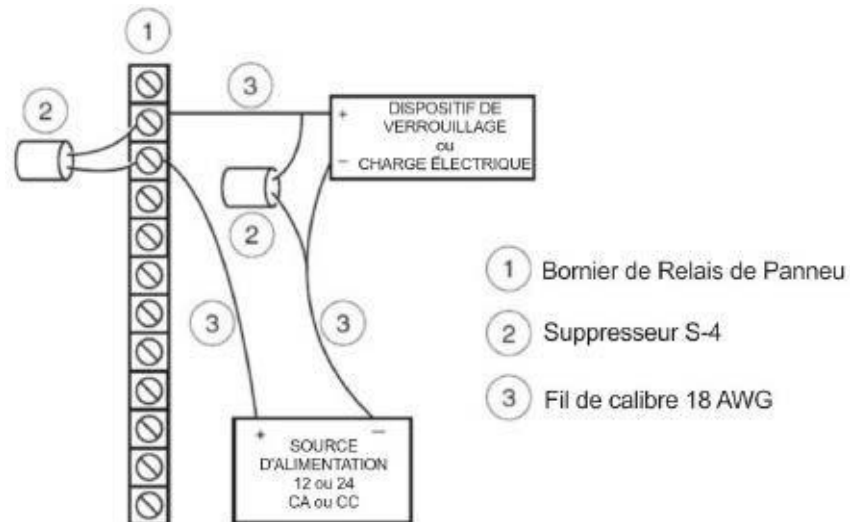

Attention:



SI L'ON CONSTATE DES DOMMAGES À L'EXPÉDITION, UNE RÉCLAMATION DOIT ÊTRE DÉPOSÉE AUPRÈS DU TRANSPORTEUR COMMERCIAL RESPONSABLE.

Attention:



Les décharges électrostatiques peuvent endommager les circuits intégrés et les modules CMOS. Pour éviter tout dommage, suivez toujours les procédures suivantes:

Utilisez des emballages et des conteneurs antistatiques pour transporter tous les composants électroniques, y compris les assemblages de lecteurs complets. Manipulez tous les composants sensibles aux décharges électrostatiques à un poste de travail approuvé pour le contrôle de l'électricité statique. Ces postes de travail se composent d'un tapis de bureau, d'un tapis de sol et d'un bracelet ESD. Les postes de travail sont disponibles auprès de différents fournisseurs.

Remarque :

Cet équipement a été testé et déclaré conforme aux limites d'un appareil numérique de classe A, conformément à la partie 15 des règles de la FCC. Ces limites sont conçues pour fournir une protection raisonnable contre les interférences nuisibles lorsque l'équipement est utilisé dans un environnement commercial. Cet équipement génère, utilise et peut émettre de l'énergie de fréquence radio et, s'il n'est pas installé et utilisé conformément au manuel d'instructions, peut causer des interférences nuisibles aux communications radio. L'utilisation de cet équipement dans une zone résidentielle est susceptible de provoquer des interférences nuisibles, auquel cas l'utilisateur devra corriger ces interférences à ses propres frais.

Remarque :

Ce document et les données qu'il contient ne doivent pas être dupliqués, utilisés ou divulgués à des tiers pour l'approvisionnement ou la fabrication, sauf autorisation écrite de Honeywell, Inc. Les informations contenues dans ce document ou dans le produit lui-même sont considérées comme la propriété exclusive et les secrets commerciaux de Honeywell, Inc. Les lois sur les droits d'auteur des États-Unis protègent toutes les informations contenues dans ce document ou dans le produit logiciel lui-même.

Remarque :

Toute utilisation de ce produit est soumise aux conditions et à l'acceptation de l'accord sur les logiciels de Honeywell, Inc. Software Agreement. Veuillez en demander une copie à Honeywell, Inc. et lisez attentivement cet accord.

Disclaimer

Product Liability; Mutual Indemnification

In the event that a Customer receives a claim that a Product or any component thereof has caused personal injury or damage to property of others, Customer shall immediately notify Honeywell in writing of all such claims. Honeywell shall defend or settle such claims and shall indemnify and hold Customer harmless for any costs or damages including reasonable attorneys' fees which Customer may be required to pay as a result of the defective Product or the negligence of Honeywell, its agents, or its employees.

Customer shall hold harmless and indemnify Honeywell from and against all claims, demands, losses, and liability arising out of damage to property or injury to persons occasioned by or in connection with the acts or omissions of Customer and its agents and employees, and from and against all claims, demands, losses, and liability for costs of fees, including reasonable attorneys' fees, in connection therewith.

Compliance

To obtain applicable EU compliance Declaration of Conformities for this product, please refer to our website, <https://www.security.honeywell.com/All-Categories/access-control-systems/control-panels-hardware>. For any additional information regarding the compliance of this product to any EU-specific requirements, please contact:

Honeywell Security & Communications
Honeywell Security - Quality Assurance Dept., Newhouse Industrial Estate
Motherwell
Lanarkshire ML1 5SB
Scotland
United Kingdom
Tel: +44(0) 1698 738200
Email: UK64Sales@Honeywell.com

CE and WEEE Marking

Description of the used symbol.



CE -Standard -Logo. This product complies with the harmonized Regulation of the EU



WEEE symbol. It indicates this product is to be recycling and not been thrown in the dustbin

Unpacking Procedure



Caution:

If any damage to the shipment is noticed before unpacking, a claim must be filed with the commercial carrier.

All containers should be opened and unpacked carefully in order to prevent damage to the contents.

The following steps are used to unpack equipment in preparation for installation:

1. Open the container and remove the unit(s) and all packing material. Retain the container and all packing materials. They may be used again for reshipment of the equipment, if needed.
2. Inspect the contents for shortage. If items are missing items, contact the order entry department at 800-323-4576.
3. Visually check contents. If damage is discovered, perform the following:
 - If shipping caused damage to the unit, a claim must be filed with the commercial carrier.
 - If any other defect is apparent, call for a return authorization.

Shipping Instructions

To ship equipment back to Honeywell, Inc.:

1. Contact the customer service department at 800-323-4576 before returning equipment. When you call please have available:
 - A description of the problem or reason you are returning the equipment.
 - Your original purchase order number, invoice number and if the unit is still under warranty.
 - A new purchase order number if the unit is not under warranty.
2. From the customer service department, obtain the Return Authorization Number (RMA).
3. Show the RMA number on all packages shipped. Packages which are not marked with an RMA number will be refused at the factory and returned to you **COD**.
4. Carefully pack the equipment for shipment. Use the original packing material whenever possible.

Limited Warranty

All Products sold or licensed by Honeywell include a warranty registration card which must be completed and returned to Honeywell by or on behalf of the end user in order for Honeywell to provide warranty service, repair, credit or exchange. All warranty work shall be handled through Customer which shall notify Honeywell and apply for a Return Merchandise Authorization (RMA) number prior to returning any Product for service, repair, credit, or exchange. Honeywell warrants that its Products shall be free from defects in materials and workmanship for a period of two years from date of shipment of the Product to Customer. The warranty on Terminals, Printers, Communications Products and Upgrade kits is 90 days from date of shipment. Satisfaction of this warranty shall be limited to repair or replacement of Products which are defective or defective under normal use. Honeywell's warranty shall not extend to any Product which, upon examination, is determined to be defective as a result of misuse, improper storage, incorrect installation, operation or maintenance, alteration, modification, accident or unusual deterioration of the Product due to physical environments in excess of the limits set forth in Product manuals. **THERE ARE NO WARRANTIES WHICH EXTEND BEYOND THIS PROVISION. THIS WARRANTY IS IN LIEU OF ALL OTHER WARRANTIES WHETHER EXPRESS, IMPLIED OR STATUTORY, INCLUDING IMPLIED WARRANTIES OF MERCHANTABILITY OR FITNESS FOR ANY PARTICULAR PURPOSE. NO REPRESENTATION OR WARRANTY OF THE DISTRIBUTOR SHALL EXTEND THE LIABILITY OR RESPONSIBILITY OF THE MANUFACTURER BEYOND THE TERMS OF THIS PROVISION. IN NO EVENT SHALL HONEYWELL BE LIABLE FOR ANY RE-PROCUREMENT COSTS, LOSS OF PROFITS, LOSS OF USE, INCIDENTAL, CONSEQUENTIAL OR SPECIAL DAMAGES TO ANY PERSON RESULTING FROM THE USE OF HONEYWELL'S PRODUCTS.**

Confidentiality

All software, drawings, diagrams, specifications, catalogs, literature, manuals and other materials furnished by Honeywell relating to the design, use and service of the Products shall remain confidential and shall constitute proprietary rights of Honeywell and Customer agrees to treat such information as confidential. Customer shall acquire no rights in the design of the Products or the related materials except to use such information solely for the purpose of and only during the time it sells the Products. Customer shall not copy the design of any of the Products or use or cause to be used any Product design or related materials for its own benefit or for the benefit of any other party. The covenants contained in this section shall remain effective throughout the term of this Agreement and thereafter unless specifically waived by Honeywell in writing.

Installing the PRO4200 Two Reader Module

Description

The PRO4200 Two-Reader Module provides support for up to two access control doors by providing connections for Wiegand or Clock/Data type readers, supervised inputs, and relay outputs. You can either mount the board in a rack or open and flat. If you rack-mount the board, only one edge is accessible for wiring; however, a flat mount increases the amount of available I/O slightly but significantly decreases the number of boards that can be mounted in one enclosure.

The I/O terminals are organized to support two doors. Starting at the bottom of the rack-mount side of the board, the connector provides power to the board and connector provides communication with the Intelligent Controller (PRO42IC and PRO32IC). The next set of terminals connects reader 2. The next set of terminals connects the I/O typically associated with reader 2, namely the Door Status and REX status inputs and the Door Lock and Lock Status relay outputs. Continuing up this edge the next two connectors provide the reader and associated I/O terminals for reader 1. The last connector on the rack-mount edge provides terminals for two additional general-purpose inputs.

When the board is mounted flat, two additional relay outputs and two additional general-purpose inputs are available along with two dedicated inputs for cabinet tamper and power fault detection on the opposite edge of the board.

The reader interface accepts a Wiegand signal of Data 1 and Data 0 or a Clock and Data signal and provides 5VDC or 12VDC reader power, a tri-stated LED control and buzzer control. Two of the six form-C relay outputs are sized for the inductive load of door locks and the other four are designed to handle dry-circuit signals. All of the inputs are capable of four-state supervision except the two dedicated inputs.

Communication to the control panel is accomplished via an RS-485 interface. This board requires 12VDC input power. When communication to the control panel is lost, this board can grant access based on facility code only. General purpose outputs will retain the setting at the time communication was lost. Up to eight facility codes may be active in each PRO32IC and PRO42IC. Keypad input must follow the reader input format and is in place of or multiplexed with the reader data.

Specification

The Two-Reader Module is for use in low voltage, class 2 circuits only.

Primary power:

12VDC + 10%, 650mA maximum with 5VDC, or 12VDC readers, 300 mA max. excluding readers

Relay contacts:

- Relays 0 and 1 outputs, Form-C, Max 5A @ 30VDC, Min ~0A @ 30VDC, resistive
- Relays 2, 3, 4, and 5 outputs, Form-C, Max 2A @ 30VDC, Min ~0A @ 30VDC, resistive

Inputs:

- 8 supervised, End of Line resistors 1k ohm \pm 1% tolerance
- 2 unsupervised dedicated inputs
- Max: 6V and Min ~0V.



Note: Inputs are closed contact inputs. For additional input wiring information, please refer to “Input Wiring“ on page 27.

Communication:

RS-485 Range 9,600 to 38,400 bps

Wire requirements:

Power	1 twisted pair, 18AWG(Honeywell 3114 or equivalent)
RS-485	24 AWG, 4,000 feet (1,200 m) max., twisted pair with shield (120 Ω , 23pF) (Honeywell 3328 or equivalent)
Inputs	1 twisted pair per input, 30 ohms max.
Outputs	As required for the load
Readers	6 conductors, 18AWG, 500 feet (150m) max. shield and drain TTL signaling requires a 6-conductor cable(18AWG) F/2F signaling requires a 4-conductor cable



Note: For OSDP cable lengths greater than 200ft(61 m), or EMF interference, install 120 Ω +/- 2 Ω resistor across RS-485 termination ends. Data 0 and Data 1 wires for wiegand maybe reused for OSDP. However, standard wiegand cable may not meet RS-485 twisted pair recommendations. The reuse of cable works best on shorter cable lengths at lower data rates.



Note: RS-485 wiring to the PW7K1R2B was evaluated in the enclosure for the ULC 60839-11-1 certification, wiring length details of 4000 ft does not apply to the Reader board PW7K1R2B. Wiring must remain inside enclosure for ULC 60839-11-1 installations.

Mechanical:

Dimension 5.5" (140 mm) W x 9" (229 mm) L x 1" (25 mm) H
Weight 12 oz. (340 g) nominal

Environment:

Temperature 0°C to +49°C, operating, -55°C to +85°C, storage
Humidity 0% to 93% RHNC

Set Up

Table 1: PRO4200 IN Module Jumper Setting

Jumper	Setting	Default	Selected
J1	OFF	*	Port 1 RS-485 EOL terminator is not active
	ON		Port 1 RS-485 EOL terminator is active
J2	Position 5		Reader 1 Power terminals provides 5 VDC
	Position 12		Reader 1 Power terminal provides 12 VDC
J3	Position 5		Reader 2 Power terminal provides 5 VDC
	Position 12	*	Reader 2 Power terminal provides 12 VDC

S8	S7	S6	S5	S4	S3	S2	S1	Selection
			OFF	OFF	OFF	OFF	ON	ADDRESS 1*
			OFF	OFF	OFF	ON	OFF	ADDRESS 2
			OFF	OFF	OFF	ON	ON	ADDRESS 3
			OFF	OFF	ON	OFF	OFF	ADDRESS 4

Installing the PRO4200 Two Reader Module
Set Up

S8	S7	S6	S5	S4	S3	S2	S1	Selection
			OFF	OFF	ON	OFF	ON	ADDRESS 5
			OFF	OFF	ON	ON	OFF	ADDRESS 6
			OFF	OFF	ON	ON	ON	ADDRESS 7
			OFF	ON	OFF	OFF	OFF	ADDRESS 8
			OFF	ON	OFF	OFF	ON	ADDRESS 9
			OFF	ON	OFF	ON	OFF	ADDRESS 10
			OFF	ON	OFF	ON	ON	ADDRESS 11
			OFF	ON	ON	OFF	OFF	ADDRESS 12
			OFF	ON	ON	OFF	ON	ADDRESS 13
			OFF	ON	ON	ON	OFF	ADDRESS 14
			OFF	ON	ON	ON	ON	ADDRESS 15
			ON	OFF	OFF	OFF	OFF	ADDRESS 16
			ON	OFF	OFF	OFF	ON	ADDRESS 17
			ON	OFF	OFF	ON	OFF	ADDRESS 18
			ON	OFF	OFF	ON	ON	ADDRESS 19
			ON	OFF	ON	OFF	OFF	ADDRESS 20
			ON	OFF	ON	OFF	ON	ADDRESS 21
			ON	OFF	ON	ON	OFF	ADDRESS 22
			ON	OFF	ON	ON	ON	ADDRESS 23
			ON	ON	OFF	OFF	OFF	ADDRESS 24
			ON	ON	OFF	OFF	ON	ADDRESS 25
			ON	ON	OFF	ON	OFF	ADDRESS 26
			ON	ON	OFF	ON	ON	ADDRESS 27
			ON	ON	ON	OFF	OFF	ADDRESS 28
			ON	ON	ON	OFF	ON	ADDRESS 29
			ON	ON	ON	ON	OFF	ADDRESS 30
			ON	ON	ON	ON	ON	ADDRESS 31
	OFF	OFF						Reserved
	OFF	ON						9,600 BPS
	ON	OFF						19,200 BPS
	ON	ON						38,400 BPS*
OFF								Not Used*

* = Default

LED Operation

The Two-Reader Module uses two onboard LEDs (D1 and D2) to provide status information during the power-up sequence as well as during normal operation. The Two-Reader Module also uses two onboard LEDs (D3 and D4) to indicate reader activity.

Table 2: LED Settings

Mode	LED D1	LED D2	Description
Power-up sequence	ON	OFF	Start power-up, hardware setup
	OFF	ON	Testing RAM
	ON	ON	Testing ROM and completing initialization
	FLASH	ON	LED D1 flashes 4 times after power-up is completed
Normal Operation	FLASH		This is the processor heartbeat LED. It flashes once every second. A short ON time (~20% duty cycle) indicates the board is offline or has lost serial communication with the Controller board. A long ON time (~80% duty cycle) indicates the board is online and communicating with the Controller board.
		FLASH	Flash when there is activity on its Serial Port.

In addition to the status LEDs, there are six additional relay status LEDs and eight input status LEDs on board. The input LEDs flash when there is a fault associated with the input. When any relay or input is energized or ON, its corresponding status LED becomes ON also. The LED remains ON for as long as the relay is energized.

The assignment for each relay status LED is shown in the following table:

The following table lists the LEDs D1 through D20.

Table 3: Additional PRO4200 Two Reader Module LEDs

LED number	Description
D3	Reader 1 activity
D4	Reader 2 activity
D5	Input 0
D6	Input 1
D7	Input 2
D8	Input 3
D9	Input 4
D10	Input 5
D11	Input 6
D12	Input 7
D13	Tampert
D14	Power
D15	Relay 0 status
D16	Relay 3 sttatus
D17	Relay 2 status
D18	Relay 4 status
D19	Relay 1 status
D20	Relay 5 status

Power

The Two-Reader Module accepts 12VDC with an operating range of 10 to 14VDC and consumes a maximum of 300mA of current without readers. Locate power source

as close to this board as possible. Connect power with minimum of 18 AWG wire. The input voltage is regulated to 5VDC. The regulated voltage or the 12VDC (pass through) is available for powering the readers. The selection is made via jumpers and is available at both reader connectors.



Note: POLARITY for 12VDC power is important. Make sure the +12 VDC is connected to the terminal labeled +12V and the return is connected to the terminal labeled GND.

Communications

The Two-Reader Module communicates to the host controller via an RS-485 interface. The interface allows for multi-drop communication of up to 4,000 feet (1,200 m) total per port. Use twisted pair (minimum 24 AWG) with shield for communication. The default speed of this port is 38.4Kbps but it can be downgraded to 19.2Kbps or 9.6Kbps if the line conditions or receiving equipment require it (see Table 1 on page 3 for jumper settings and Table 2 on page 4 for DIP switch settings).

For wiring to an RS-485 port:

1. TR+ is the plus side of the transmit and receive differential signal.
2. TR- is the negative side of the transmit and receive differential signal.
3. GND is the signal ground. The wiring for this signal is required and NOT optional. This signal must NOT be connected to chassis GND.

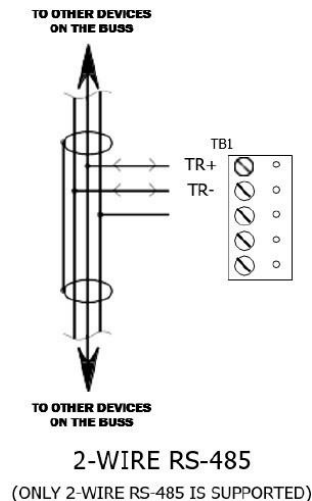

4. Use 24 AWG low capacitance, twisted-pair, shielded cable (Honeywell 3328 or equivalent).

Wiring

This section presents information on reader wiring, input wiring, and control output wiring.

The following figure shows the PRO4200 board and identifies its terminal block pin assignments.

Figure 1: PRO4200 Two Reader Module (PRO42R2) Wiring: Connectors TB1-TB7.

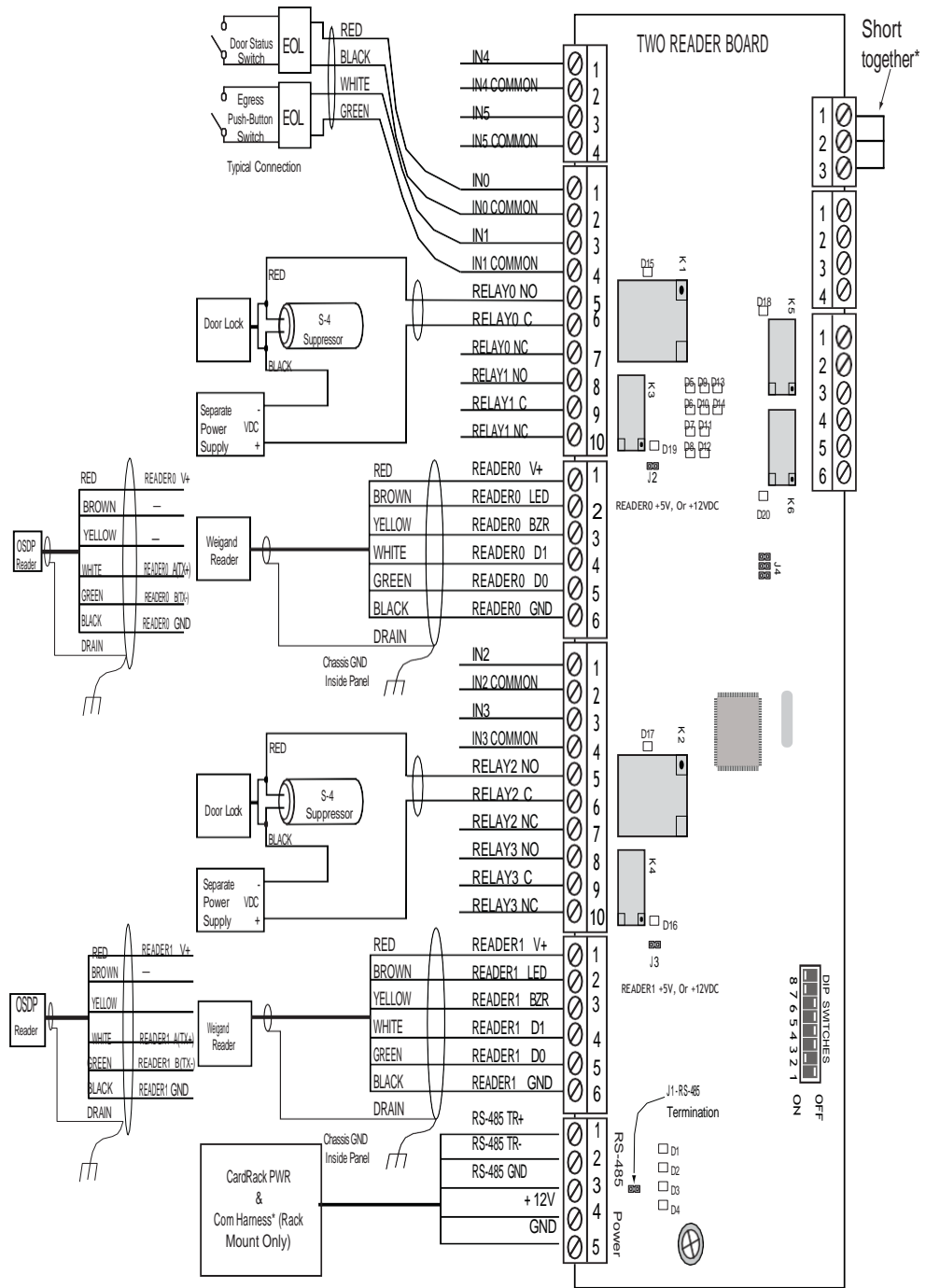

* Rack Mount Configuration

Installing the PRO4200 Two Reader Module
 Wiring Diagram for Connectors TB1, TB7-9

**Figure 2: PRO4200 Two Reader Module (PRO42R2) Wiring:
 Connectors TB1, TB7-TB9.**

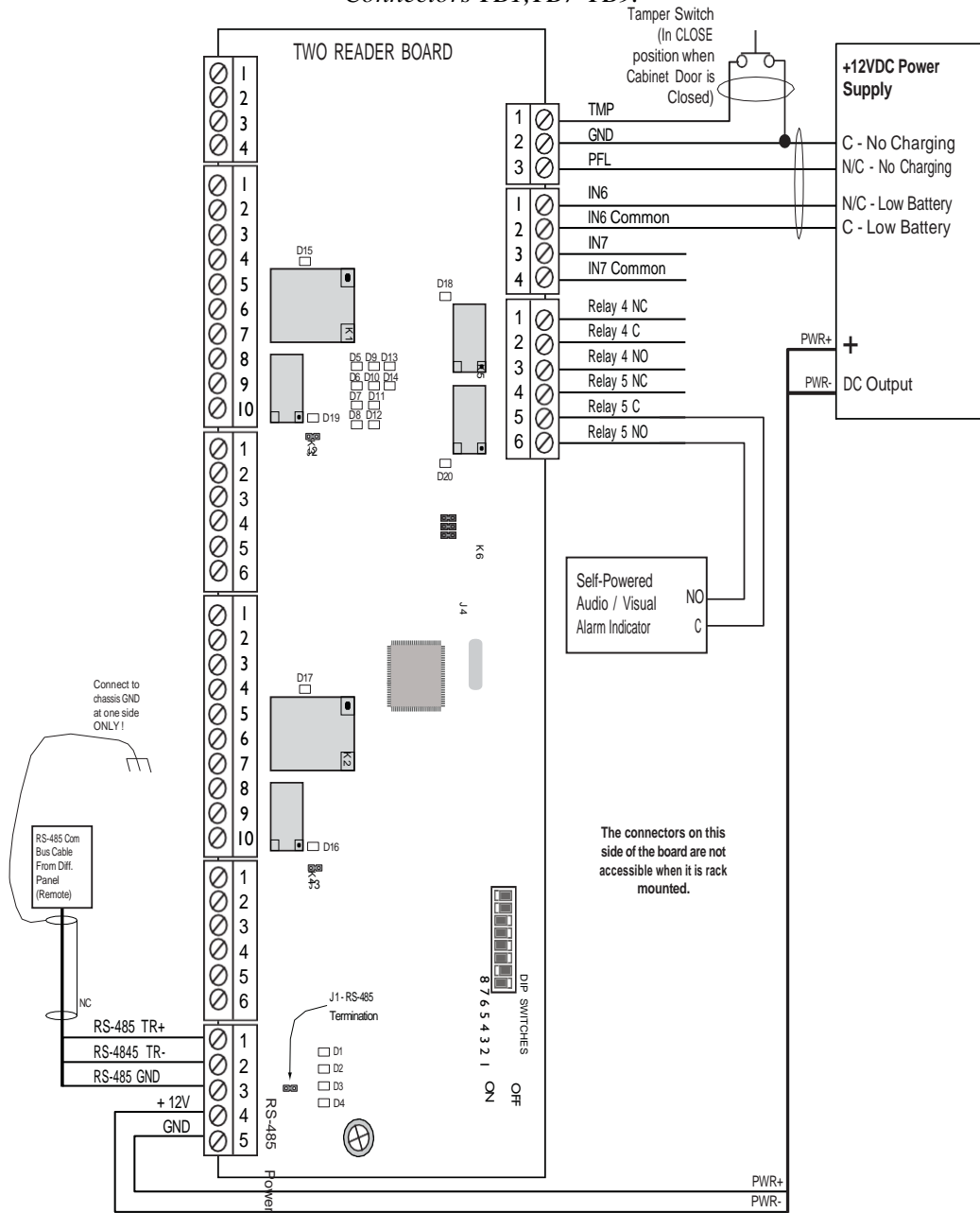

Note: See [Section , "LED Operation"](#) on page 15 for descriptions of LEDs D1-D20.

Note: Reader, Input, and Output addresses on the PRO4200 panel are labeled starting with address 0. This translates to address 1 in the WIN-PAK per the example below:

PRO4200 Device	PRO4200 Address	WIN-PAK Address
----------------	-----------------	-----------------

Installing the PRO4200 Two Reader Module
Wiring Diagram for Connectors TB1, TB7

Reader\ Input\ Output	0	1
Reader\ Input\ Output	1	2

Note: The SIO board port for a PRO42IC in WIN-PAK is port 6 and is set as the default.

Figure 3: PRO4200 Two Reader Module (PRO42R2B) Wiring: Connectors TB1-TB7.

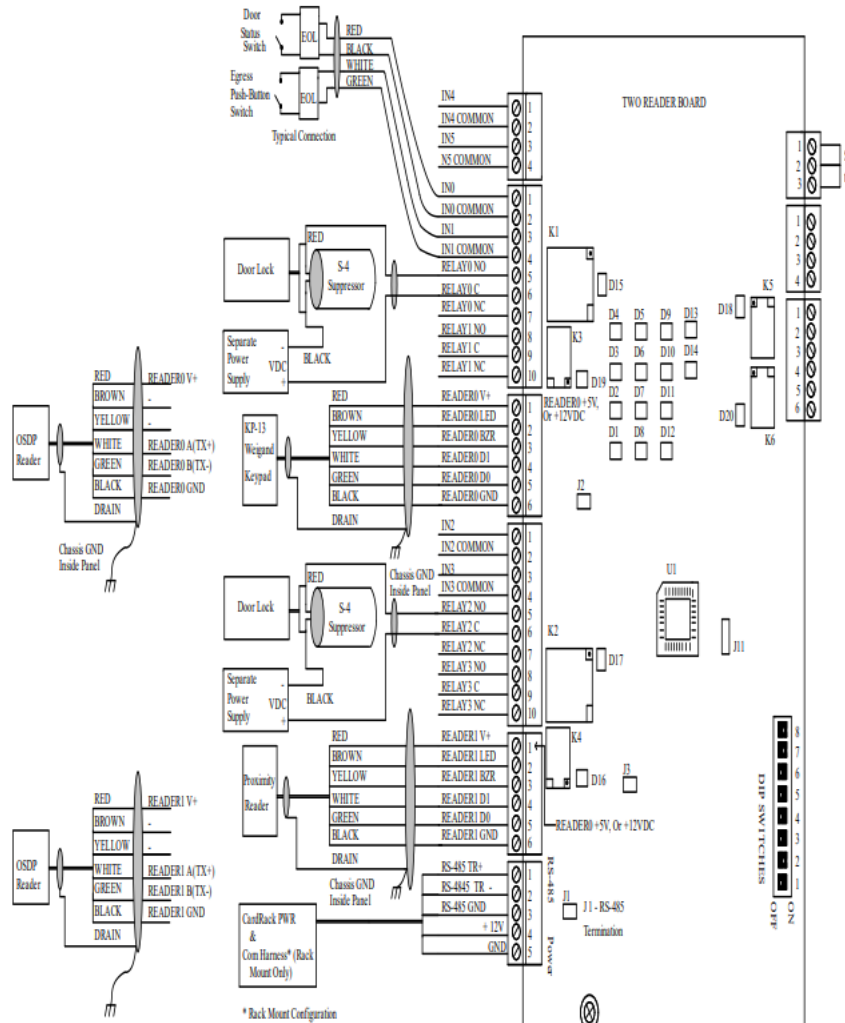

Installing the PRO4200 Two Reader Module
 Wiring Diagram for Connectors TB1, TB7

Figure 4: PRO4200 Two Reader Module (PRO42R2B) Wiring:
 Connectors TB1, TB7-TB9.

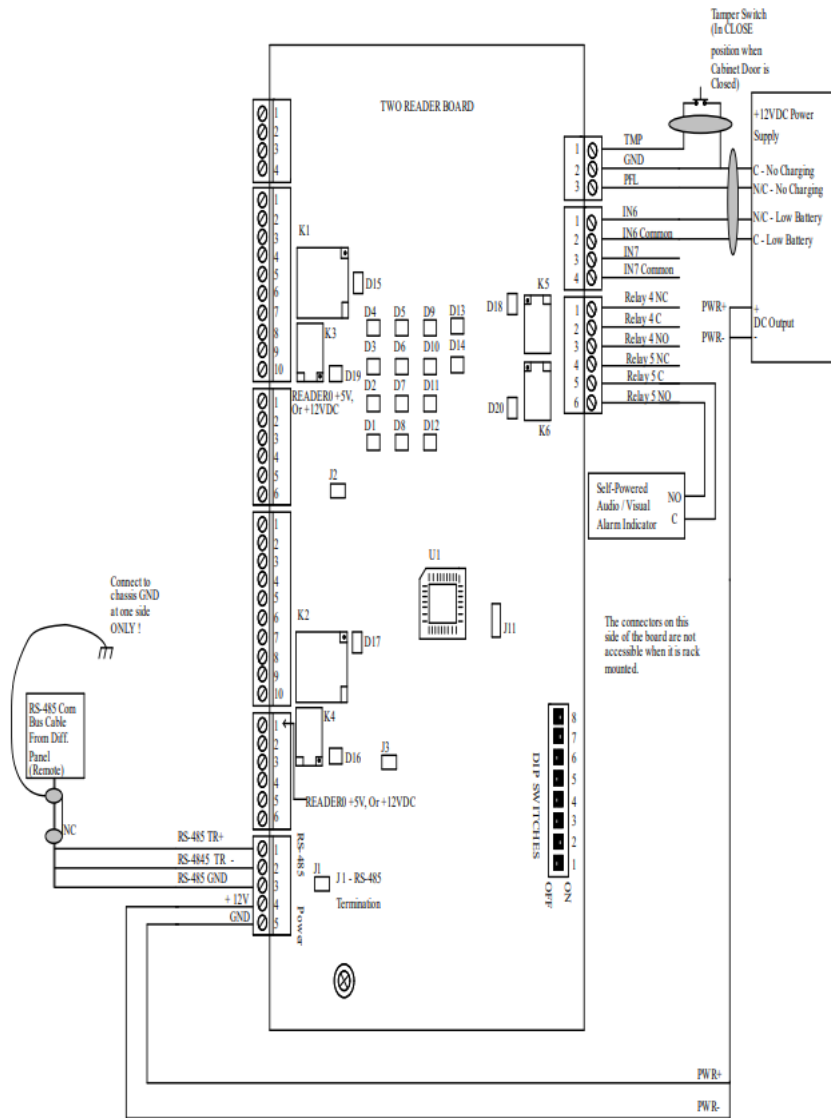

Note: See Section , "LED Operation" on page 15 for descriptions of LEDs D1-D20.

Installing the PRO4200 Two Reader Module
Wiring Diagram for Connectors TB1, TB7-9

Each reader port supports a reader with TTL (D1/D0, Clock/Data), or 2-wire RS-485 signaling. Power to the reader is selectable:

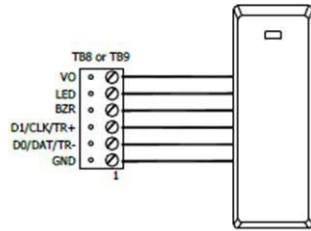

Typical D1/D0 – Clock/Data Reader

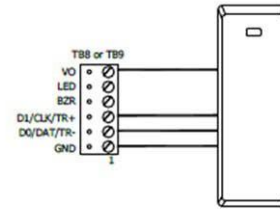

**Typical 2-Wire RS-485 Device
(OSDP Reader for Example)**

Input on supervised F/2F readers may be unsupervised or supervised (supervised shown).

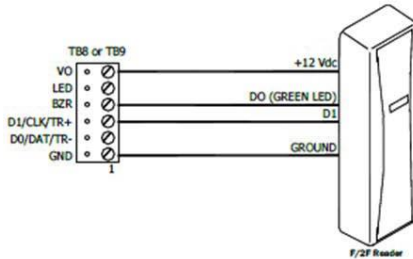

Typical Unsupervised F/2F Reader

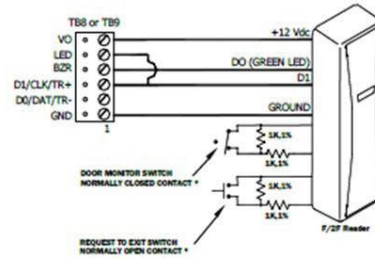

Typical Supervised F/2F Reader

Reader Wiring

The following Honeywell reader modul numbers have been approved by UL for use with the PRO4200: OS20TOSDP, OS20KTOSDP, OS40TOSDP, OS40KTOSDP.

Each reader port supports a reader with TTL interface. Power to the reader is selectable as 5VDC or 12VDC (pass-through). This selection is done by setting the jumpers J7 for reader 1 and J8 for reader 2. Set jumper at position "5" for 5VDC or "12" for pass-through 12VDC. The factory defaults set J7 and J8 to "12".

For wiring to a reader port

Table 4: Settings for Wiring to a Reader Port

Terminal	Typical Wire Color	Wiegand Reader	Clock/Data Readers	OSDP Reader
1	Red	Power (5 or 12 Vdc)	Power (5 or 12 Vdc)	Power (12 Vdc)
2	Brown	LED control	LED control	-
3	Yellow	Beeper Control	Beeper Control	-
4	White	Data 1 Signal	Clock Signal	A Signal (TX+)
5	Green	Data 0 Signal	Data 0 Signal	B Signal (TX-)
6	Black	Common	Common	Ground

The LED control terminal in each reader port can be configured via host software to support one-wire single or bi-colored reader LED. An example of the most common configuration is shown below. If Beeper Control is not used, its terminal can be programmed to be the second wire for the two-wire bi-colored reader LED.

Table 5:

LED Output->	High	Tri- Stated	Low
Single Color LED	LED ON	LED OFF	LED OFF
Bi- Color LED	Green LED ON	Both LEDs OFF	Red LED ON

To fully utilize each reader port, a 6-conductor cable (18AWG) is required. Reader port configuration is set via host software

Input Wiring

Inputs 0 to 7 may be configured to use normally open or normally closed contacts and non-supervised or supervised (with standard $\pm 1\%$ tolerance 1K ohm). Four of these inputs have default functional definitions, but all eight can be configured to monitor general-purpose sensors.

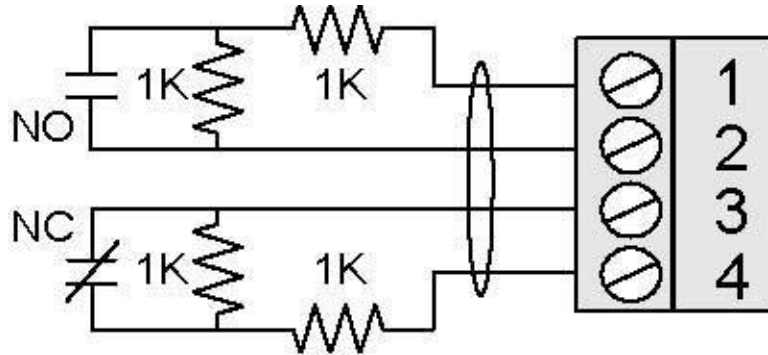

By default, Input 0 is defined as the Door Status Input corresponding to reader 1 and Input 1 is defined as the REX input corresponding to reader 1. Also by default, Input 2 is defined as the Door Status Input corresponding to reader 2 and Input 3 is defined as the REX input corresponding to reader 2. Inputs 4, 5, 6 and 7 are general purpose inputs that can be used to monitor sensors or as control inputs. Inputs 6 and 7 are not accessible when the board is rack mounted.

Inputs TMP and PFL are typically used for monitoring cabinet tamper and power failure respectively. These two inputs are not supervised and are not accessible when the board is rack-mounted. These inputs were primarily provided for the case when this board is mounted remotely and cannot take advantage of the tamper and power fail detect inputs on the controller board. If these inputs are not used, install a short piece of wire at the input to indicate safe condition.

Input configuration including debounce and hold time is set via host software.

Control Output Wiring

Six form-C relay contacts are provided for controlling door strike or other devices. Each may be assigned to door-related functions or general-purpose output. They are configurable as standard (energize to activate) or fail-safe (de-energize to activate) via host software.

The energized or ON time of each relay can be configured using Pulse control for single or repeating pulses via host software. The energized or ON time for a single pulse can be extended up to 24 hours. For repeating pulses, the on/off time can be defined in 0.1 second increments and be repeated up to 255 times.

1. Relays 0 and 2 are rated for and normally used to control the door locks associated with readers 0 and 1 respectively. While Relays 0 and 2 are sized to handle the typical loads generated by electrical locks, load switching can cause abnormal contact wear and premature contact failure. Switching of inductive loads (i.e., strike) also causes numEMI (electromagnetic interference) which may interfere with normal operation of

other equipment. To minimize premature contact failure and to increase system reliability, a contact protection circuit is highly recommended. The following two circuits are suggested. Locate the protection circuit as close to the load as possible (within 12 inches [30cm]); the effectiveness of the circuit decreases as the distance from the load increases.



Note: Only relays 0 and 2 can be used for door hardware in a UL installation

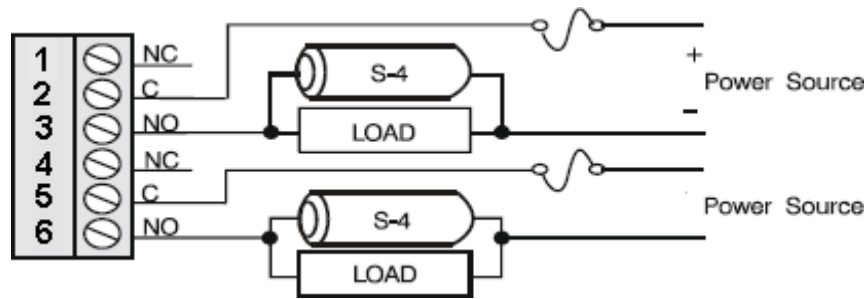

Relays 1 and 3 are dry-circuit level signal relays typically used to indicate the status of the door lock. Relays 4 and 5 are general-purpose relay outputs and are not available when the board is rack-mounted.

Use sufficiently large gauge of wires for the load current to avoid voltage loss.

Mounting Options

This board can be mounted on-edge in the rack-mount enclosure provided by Honeywell or it can be mounted flat against any surface using standoffs under the mounting holes provided in each of the four corners of this board.

When this board is rack-mounted, the connectors for two general-purpose inputs, two general-purpose outputs, and two dedicated inputs are not accessible and should not be used.

The most common reason for mounting a board flat is that it is being installed remotely to be located near the door(s) being monitored. In this case it will be mounted in its own enclosure creating the need to monitor cabinet tamper and power fault detection inputs. The two additional general-purpose inputs and outputs provided allow for the monitoring of extra sensors and control of local horns or other equipment.

Installing the Module

1. Set Jumpers and DIP switches.
2. Mount this board in the appropriate enclosure - If this board is being mounted in a rack, the component side of the board is to your right as you face the rack.
3. Connect the communications and power supply to the circuit boards with the Power Supply Harness.



Warning: DO NOT CONNECT THE POWER SUPPLY TO THE AC SOCKET UNTIL ALL WIRING HAS BEEN INSTALLED AND RECHECKED.

4. Connect wiring to the reader interfaces as appropriate.
5. Connect wiring to input sensors or install jumper wire as appropriate.
6. Connect relay output wiring as appropriate.
7. Connect communications wiring to the Intelligent Controller.
8. Recheck wiring for correct connections and continuity.
9. When all boards have been installed, connect the power supply cord for proper
10. connections and power.
11. Set up the panel controls using the host software.

(This page is left blank intentionally for double-sided printing.)

2-Reader Input Module Programming Guide

PRO42R2/PRO42R2B-Reader Input Module Programming Sheets:

Project Name	
Location / Country	
Host IC Board	0
Board Description	
PW Panel RS485 Port	3
Board Address	0
Location	
Floor	
Cabinet Location	
Tamper Input	Connected
Powerfail	Shunted
Termination Jumper J1	Not Active

RS485 Port +	Power Connector	Connected Cable #	Cable Destination	Conductor Color
RS485 TX (+)	Pin #1			
RS485 RX (-)	Pin #2			
Common	Pin #3			

Power	Power Connector	Connected Cable #	Cable Destination	Conductor Color
Power (+)	Pin #1			
Power (-)	Pin #2			

Inputs 4 and 5	Connected Cable #	Cable Destination	Conductor Color
Input 4	Pin #1		
Input 4 Com	Pin #2		
Input 5	Pin #3		
Input 5 Com	Pin #4		

Door 1 Input / Output	Connected Cable #	Cable Destination	Conductor Color
Input 0	Pin #1		
Input 0 Com	Pin #2		
Input 1	Pin #3		
Input 1 Com	Pin #4		
Relay 0 No	Pin #5		

2-Reader Input Module Programming Guide

Door 1 Input / Output		Connected Cable #	Cable Destination	Conductor Color
Relay 0 Com	Pin #6			
Relay 0 NC	Pin #7			
Relay 1 No	Pin #8			
Relay 1 Com	Pin #9			
Relay 1 NC	Pin #10			

Reader 1 WIN-PAK Reader 1 (the reader address used in the WIN-PAK hardware setup)				
VDC Select J2	5 Volt	Connected Cable #	Cable Destination	Conductor Color
DC Out (+)	Pin #1			
Red LED	Pin #2			
Beeper Ctrl	Pin #3			
Data - 1	Pin #4			
Data - 0	Pin #5			
Common	Pin #6			
Note: Reader 0 is Reader 1 in WIN-PAK				

Door 2 Input / Output		Connected Cable #	Cable Destination	Conductor Color
Input 2	Pin #1			
Input 2 Com	Pin #2			
Input 3	Pin #3			
Input 3 Com	Pin #4			
Relay 2 No	Pin #5			
Relay 2 Com	Pin #6			
Relay 2 NC	Pin #7			
Relay 3 No	Pin #8			
Relay 3 Com	Pin #9			
Relay 3 NC	Pin #10			

Reader 2 WIN-PAK Reader 2 (the reader address used in the WIN-PAK hardware setup)				
VDC Select J2	5 Volt	Connected Cable #	Cable Destination	Conductor Color
DC Out (+)	Pin #1			
Red LED	Pin #2			
Beeper Ctrl	Pin #3			
Data - 1	Pin #4			
Data - 0	Pin #5			
Common	Pin #6			
Note: Reader 1 is Reader 2 in WIN-PAK				

Inputs 6 and 7		Connected Cable #	Cable Destination	Conductor Color
Input 6	Pin #1			
Input 6 Com	Pin #2			
Input 7	Pin #3			
Input 7 Com	Pin #4			

Inputs 4 and 5		Connected Cable #	Cable Destination	Conductor Color
Relay 4 NC	Pin #1			
Relay 4 Com	Pin #2			
Relay 4 NO	Pin #3			
Relay 5 NC	Pin #4			
Relay 5 Com	Pin #5			
Relay 5 NO	Pin #6			

(This page is left blank intentionally for double-sided printing.)

For more information: www.honeywellaccess.com

Technical Support Self-Service | Customer Portal

<https://myhoneywellbuildingsuniversity.com/training/support/>

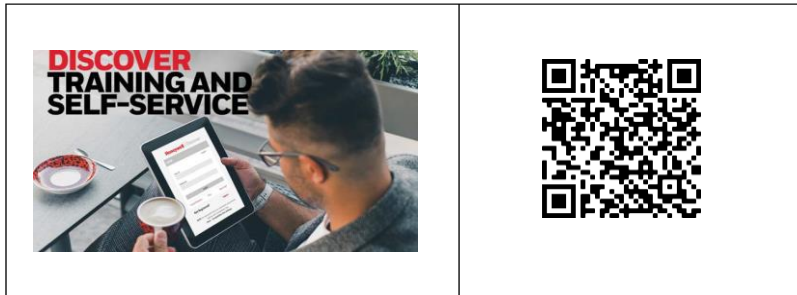

YouTube | Honeywell Help and Support

https://www.youtube.com/channel/UCBEL6ouNV_LN5IEpYRujMTg/featured

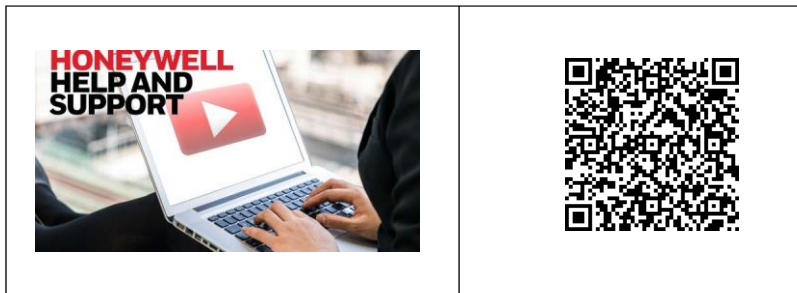

Honeywell Access Systems

135 W. Forest Hill Avenue
Oak Creek, WI 53154
United States
800-323-4576
414-766-1798 Fax
www.honeywellaccess.com

Specifications subject to change
without notice.

Document:800-25698V2

© 2022 Honeywell. All rights reserved.

Honeywell

—
**THE
FUTURE
IS
WHAT
WE
MAKE IT**

REJECTION RESPONSE SHEET

07/02/2025

RESPONSE TO COMMENTS

Select Medical

- 1) All devices are UL294 Listed. The Pro 4200 has it only on their Brochure. See PDF attachment with all devices.
- 2) The Power Supply has been marked and clouded to show Its location (Scope of Work).
See TY101
- 3) No relay is needed. No maglocks for this project. See TY 101 and TY102
- 4) No Sprinkler system for this Job. See TY102
- 5) All the remarks have been addressed.

REJECTION RESPONSE SHEET

07/02/2025

RESPONSE TO COMMENTS

Select Medical

- 1) All devices are UL294 Listed. The Pro 4200 has it only on their Brochure. See PDF attachment with all devices.
- 2) The Power Supply has been marked and clouded to show its location (Scope of Work). See TY101
- 3) No relay is needed. No maglocks for this project. See TY 101 and TY102
- 4) No Sprinkler system for this Job. See TY102
- 5) All the remarks have been addressed.



Address: 14001 NW 82 AVE
Folio #: 3220220400020
MDC Process #: M2025016727
MDC Tracking #: 3225016727
Job Description: ACCESS CONTROL

Master Permit #: **BLC2024-0975**

Sub Permit #: **SEL2025-1459**

Revision #:

OFFICE USE ONLY

ZONING	<input type="checkbox"/> Approved	Date	Disapproved	BUILDING	<input type="checkbox"/> Approved	Date	Disapproved	STRUCT.	<input type="checkbox"/> Approved	Date	Disapproved
	Date				Date				Date		
	Initials				Initials				Initials		
ROOFING	<input type="checkbox"/> Approved	Date	Disapproved	ELECT.	<input type="checkbox"/> Approved	Date	Disapproved	MECH.	<input type="checkbox"/> Approved	Date	Disapproved
	Date				Date				Date		
	Initials				Initials				Initials		
PLUMBING	<input type="checkbox"/> Approved	Date	Disapproved	FLOOD	<input type="checkbox"/> Approved	Date	Disapproved		<input type="checkbox"/> Approved	Date	Disapproved
	Date				Date				Date		
	Initials				Initials				Initials		

PLANS CHECKED-OUT

DATE	NAME

PLANS CHECKED-IN

DATE	NAME

	AMOUNTS
BASE PERMIT	
ZONING FEE	
CODE COMPLIANCE FEE	
TECHNOLOGY FEE	
DBPR SURCH. STATE	
DBPR SURCH. BUILDING	
SCANNING FEE	
WORK W/O PERMIT FEE	
UPFRONT FEE PAID	
BALANCE DUE:	

Select Medical
14972521-02



6601 Main St • Miami Lakes, Florida, 33014
Office: (305) 827-4015 • Fax: (305) 558-9884
Website: www.miamilakes-fl.gov

BUILDING PERMIT APPLICATION

Job Address: 14001 NW 82ave

Unit #:

Folio #: 32-2022-040-0028 Owner-Builder:

Master Permit #: BLC2024-0975 Sub Permit #: SEL2025-1459 Revision #: _____

OWNER INFORMATION	NAME: <u>TGC LLC</u>	LEGAL USE/WORK	Current Use of Property: <u>Commercial</u>
	Address: <u>6843 Main St</u>		Job Description: <u>Access Control</u>
	City, State, Zip: <u>Miami Lakes FL 33015</u>		JOB COST \$ <u>38109.00</u> AREA/LENGTH: _____ SF/LF
	Phone #: _____ Cell #: _____		Residential <input type="checkbox"/> Multi-Family <input type="checkbox"/> Commercial <input type="checkbox"/> Industrial <input checked="" type="checkbox"/>
Email Address: _____		Occupancy: _____	
Company Name: JOHNSON CONTROL SECURITY SOLUTIONS		Construction Type: _____	
Qualifier Name: FITZPATRICK, JASON ALEXANDER		Flood Zone/B.F.E.: _____ F.F.E.: _____	
CONTRACTOR INFORMATION	License # <u>EF20000452</u>	ARCHITECT/ENGINEER	Firm Name: _____
	Address <u>15901 SW 29th Street #801</u>		A/E of record: _____
	City, State, Zip <u>Miramar, FL, 33027</u>		License # _____
	Phone #: <u>954-624-9824</u> Cell #: _____		Address _____
	Email Address: <u>Outi.battenfield@jci.com</u>		City, State, Zip _____
Permit Type -- Check only One		Change to Permit -- Check only One	
<input type="checkbox"/> Building <input checked="" type="checkbox"/> Electrical <input type="checkbox"/> Mechanical <input type="checkbox"/> Plumbing/Gas <input type="checkbox"/> Paving/Drainage <input type="checkbox"/> Sign <input type="checkbox"/> Roofing <input type="checkbox"/> P/W		<input type="checkbox"/> Extension <input type="checkbox"/> Renewal <input type="checkbox"/> Revision <input type="checkbox"/> Change Contractor <input type="checkbox"/> Shop Drawing <input type="checkbox"/> Cancellation	

Application is hereby made to obtain a permit to do work and installation as indicated. I certify that no work or installation has commenced prior to the issuance of a permit and that all work will be performed to meet the standards, of all laws regulating construction in this jurisdiction. I understand that a separate permit must be secured for ELECTRICAL WORK, MECHANICAL, PLUMBING, SIGNS, WELLS, POOLS, RE-ROOFING, SHUTTERS, WINDOWS, FURNACES, BOILERS, HEATERS, TANKS, and AIR CONDITIONERS, etc. I understand that in signing this application I am responsible for the supervision and completion of the construction including scheduling of inspections and obtaining final inspections in accordance with the plans and specification WARNING TO OWNER: YOUR FAILURE TO RECORD A NOTICE OF COMMENCEMENT MAY RESULT IN YOU PAYING TWICE FOR IMPROVEMENTS TO YOUR PROPERTY. IF YOU INTEND TO OBTAIN FINANCING, CONSULT WITH YOUR ATTORNEY OR LENDER BEFORE RECORDING YOUR NOTICE OF COMMENCEMENT. OWNER/CONTRACTOR AFFIDAVIT: I Certify that all the foregoing information is accurate and that all work will be done in compliance with all applicable laws regulating construction and zoning.

X
Signature of Owner or Owner's Agent _____ Date _____

X [Signature] 11-18-24
Signature of Qualifier _____ Date _____

Print Name of Owner or Owner's Agent _____

FITZPATRICK, JASON ALEXANDER
Print Name of Qualifier _____

STATE OF _____ COUNTY OF _____
Sworn to and subscribed before me this _____ 20____
by _____ (SEAL)
Personally known or I.D. _____

STATE OF FLORIDA COUNTY OF Broward
Sworn to and subscribed before me this 11-18 2024
by Jason Fitzpatrick (SEAL)
Personally known or I.D. _____

NOTICE: In addition to the requirements of this permit, there may be additional deed restrictions enforced by the homeowner's associations that may be applicable to this property that may be found in the public records of this county, and there may be additional permits required from other governmental entities such as water management districts, state agencies, or federal agencies.

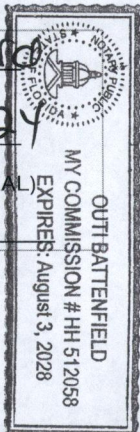

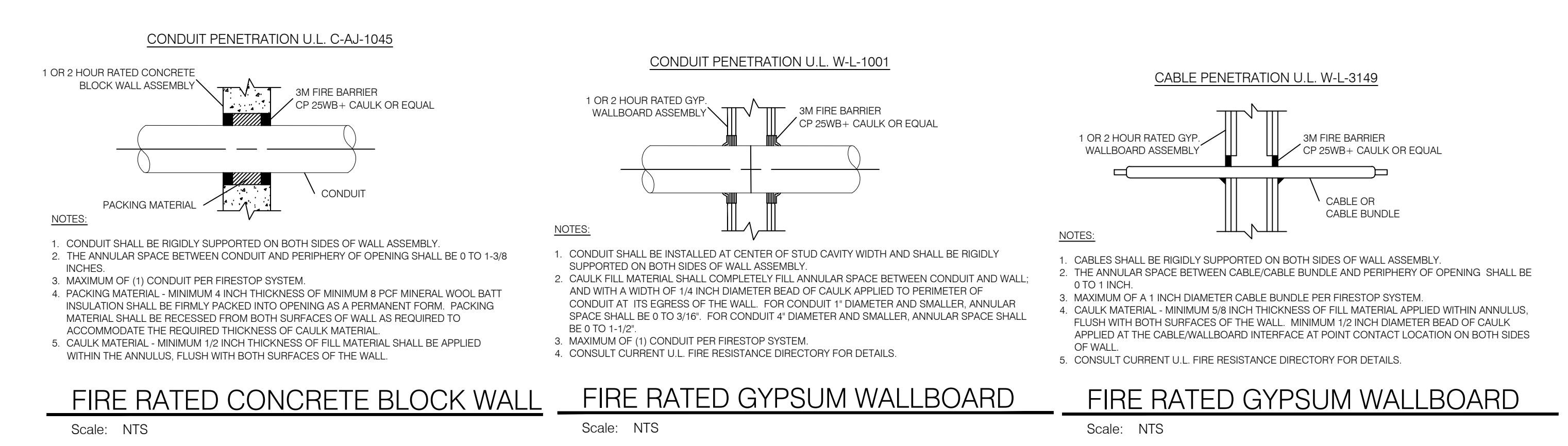
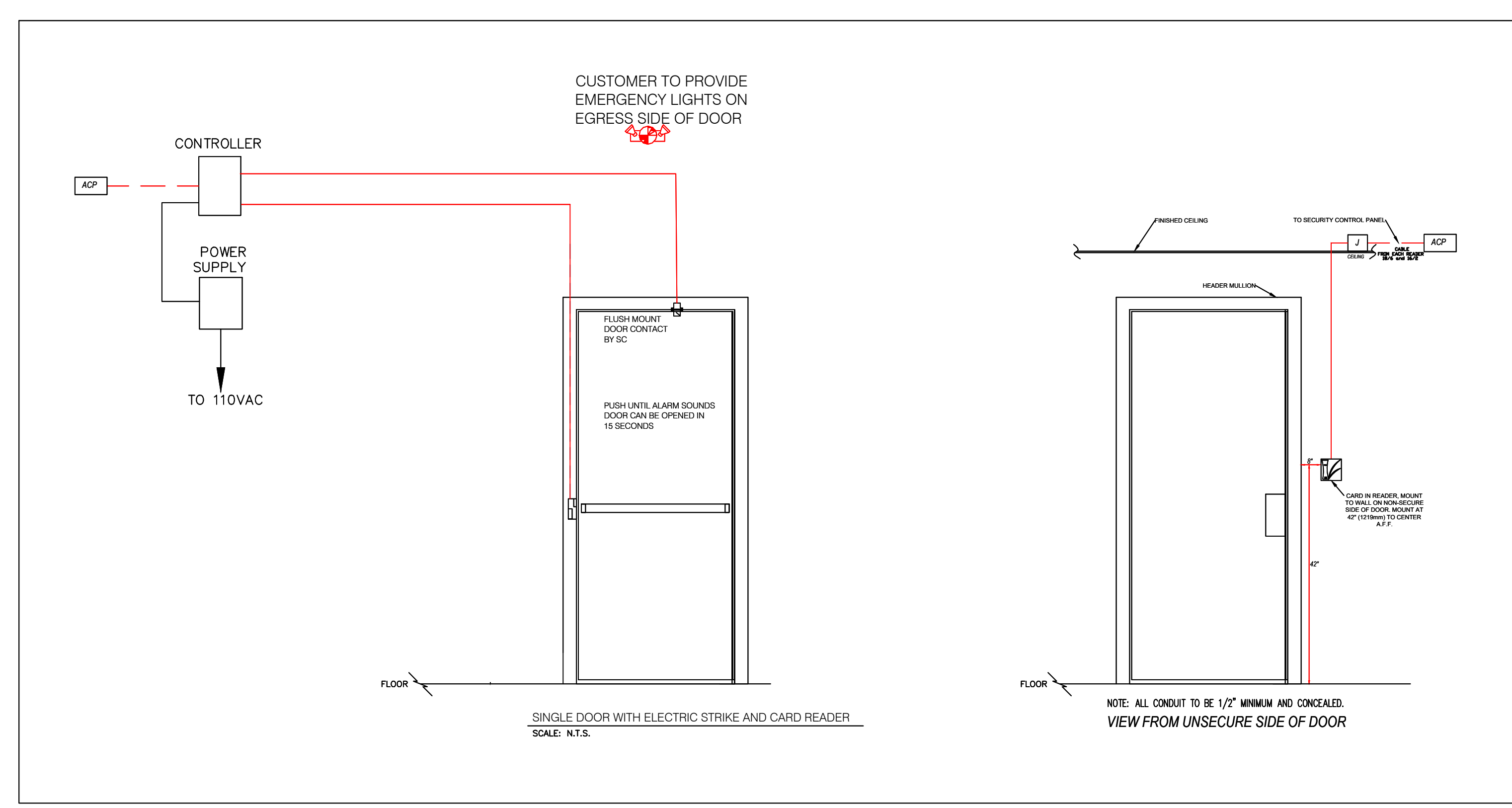
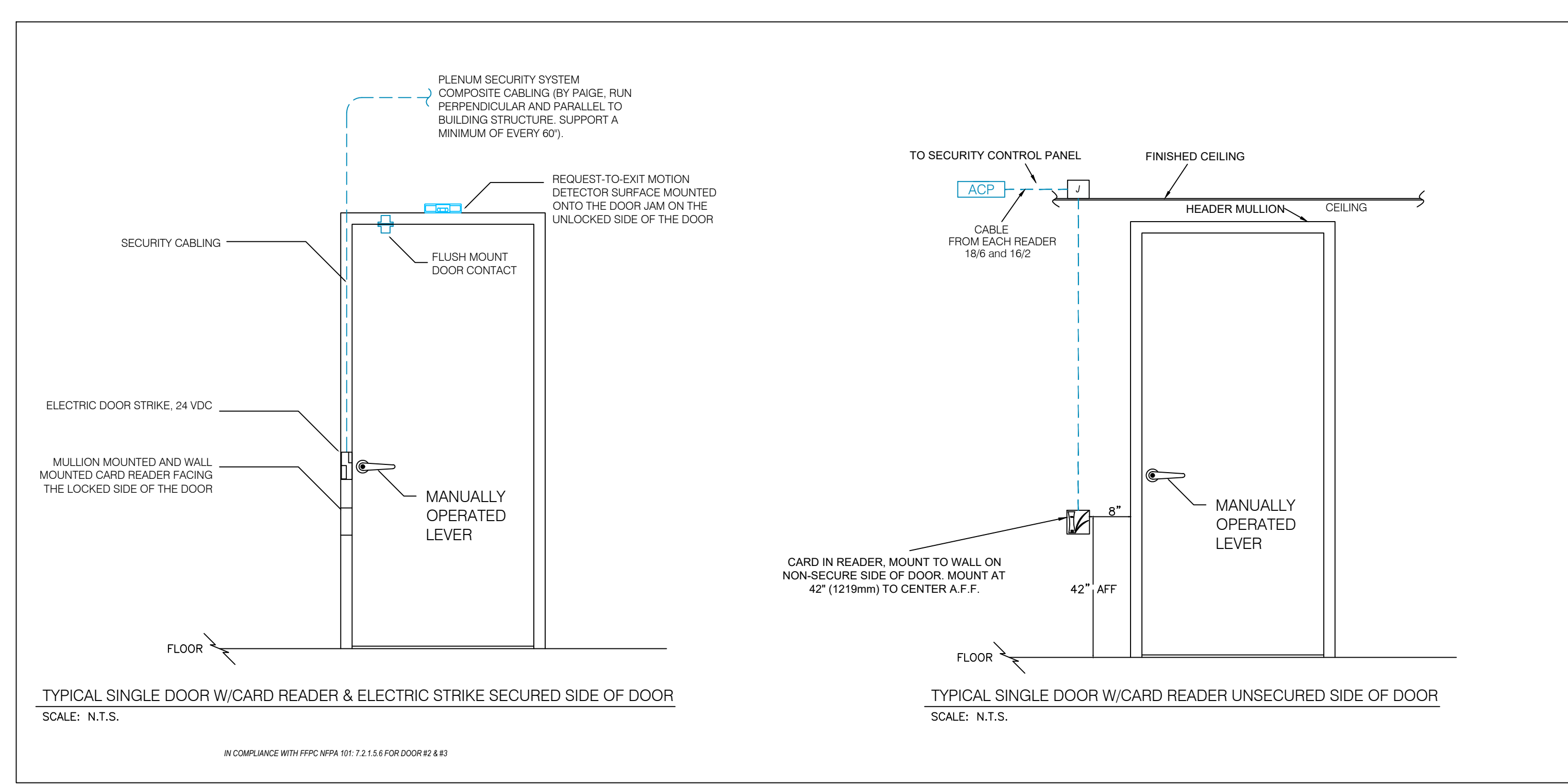

CODES IN EFFECT AT THE TIME OF THIS PLANS SUBMISSION ARE
NEC 2020 AND FBC 2023 (8TH EDITION)
FIRE PREVENTION CODE 2023 (8TH EDITION)
NFPA 72: NATIONAL FIRE CODE (2019 EDITION)
NFPA 101: (2021 EDITION)
LIFE SAFETY CODE (2021 EDITION)

NFPA-101 2021 EDITION
ELECTRICALLY CONTROLLED EGRESS DOOR ASSEMBLIES
 7.2.1.6.3.1 DOOR HARDWARE RELEASE OF ELECTRICALLY LOCKED EGRESS DOOR ASSEMBLIES. DOOR ASSEMBLIES IN THE MEANS OF EGRESS SHALL BE PERMITTED TO BE EQUIPPED WITH APPROVED ELECTRICAL LOCKING SYSTEMS RELEASED BY THE OPERATION OF DOOR HARDWARE PROVIDED THAT ALL OF THE FOLLOWING CONDITIONS ARE MET.
 (1) THE HARDWARE FOR EGRESS-SIDE OCCUPANT RELEASE OF THE ELECTRICAL LOCK IS AFFIXED TO THE DOOR LEAF.
 (2) THE HARDWARE HAS AN OBVIOUS METHOD OF OPERATION THAT IS READILY OPERATED IN THE DIRECTION OF EGRESS UNDER ALL LIGHTING CONDITIONS.
 (3) THE HARDWARE IS CAPABLE OF BEING OPERATED WITH ONE HAND IN THE DIRECTION OF EGRESS.
 (4) OPERATION OF THE HARDWARE DIRECTLY INTERRUPTS THE POWER SUPPLY DIRECTLY TO THE ELECTRIC LOCK AND UNLOCKS THE DOOR ASSEMBLY IN THE DIRECTION OF EGRESS.
 (5)* LOSS OF POWER TO THE LISTED RELEASING HARDWARE AUTOMATICALLY ELECTRICALLY UNLOCKS THE DOOR ASSEMBLY IN THE DIRECTION OF EGRESS.
 (6) HARDWARE FOR NEW INSTALLATIONS IS LISTED IN ACCORDANCE WITH ANSI/UL 294, STANDARD FOR ACCESS CONTROL SYSTEM UNITS.

NFPA-101 2021 EDITION
LOOKS, LATCHES, AND ALARM DEVICES.
 7.2.1.5.3.
 LOOKS, IF PROVIDED, SHALL NOT REQUIRE THE USE OF A KEY, A TOOL, OR SPECIAL KNOWLEDGE OR EFFORT FOR OPERATION FROM THE EGRESS SIDE

SCOPE OF WORK

- PROVIDE, INSTALL, CONNECT & TEST ACCESS CONTROL EQUIPMENT INCLUDING CONTROL PANEL, POWER SUPPLY, CARD READERS, REQUEST TO EXIT MOTION DETECTORS AND ELECTRIC STRIKE BY OTHERS.
- PROVIDE & INSTALL ALL WIRE & CABLE NECESSARY FOR A COMPLETE ACCESS CONTROL SYSTEM, INCLUDING CONNECTION TO DEVICES PROVIDED BY OTHERS. & ELECTRIC DOOR STRIKES.
- PROVIDE & INSTALL, 20 DEVICES & 1 ACCESS CONTROL.

ACCESS CONTROL LEGEND

QTY	SYMBOL	DESCRIPTION	PART # CATALOG #	MANUFACTURER
1	[ACU]	ACCESS CONTROL UNIT	PRO4200	HONEYWELL
1	[PWS]	POWER SUPPLY	AL600ULACM	ALTRONIX
5	[DS]	DOOR STRIKE	HES 8000	BY LOCKSMITH
5	[DC]	DOOR CONTACT	180-12-B	GRI
5	[CR]	CARD READER	RP40	HID
4	[RE]	REQUEST TO EXIT PIR	DS160 SERIES	BOSSCH

